

A Supplement to I&E News, March 1, 2010

# TECHNORAMA

FOR PROFESSIONAL ENGINEERS AND DECISION MAKERS



Intelligent Motion Control

### Who does IEI serve

IEI functions among professional engineers, academicians and research workers. It provides a vast array of technical, professional and supporting services to the Government, Industries, Academia and the Engineering fraternity, operating from over 100 centres located across the country.

### Does IEI offer educational courses

IEI offers a non-formal engineering course, the successful completion of which is officially recognized as equivalent to a degree in engineering or a post-graduate diploma leading to a master's degree. Every year, as many as 60,000 candidates appear for these exams which are held bi-annually at examination centres in India and abroad.

### What is the IEI mission

To promote and advance the science practice and business of engineering in all its various disciplines.

### What can IEI do for you

IEI provides all that you need to further your professional career as an engineer.

Among them are :

- Continuous professional development through regular professional programmes in India and abroad
- Opportunities to update professional knowledge through courses conducted by IEI's Engineering Staff College of India at Hyderabad
- A chance to participate in interdisciplinary activities in the fields of rural development, sustainable development, water management, quality, safety and R&D
- Rights and privileges of being a Chartered Engineer
- Participation opportunities in national and international seminars, meets, conferences and other activities

## Editorial

**K**eeping pace with the outstanding technological achievement of the twentieth-century, revolutionary progress has been made in the performance improvement of Motion Control Technology through implementation of power electronics combined with mini- and microcomputers, microprocessors, DSP technology and now, FPGA's. Besides significant cost reductions in control electronics, reliability and flexible software control these devices are also being made to enhance and optimize the motion control performance further by intelligent, self-learning or self-organizing control utilizing artificial intelligence techniques like expert systems, fuzzy logic and neural network techniques with embedded protection and smart devices —thus emerging a new breed of Intelligent Motion Control Technology.



We at The Institution of Engineers (India) always endeavour to bring you the happenings and latest development in the area of technology through the publication of theme based issues of Technorama. While the last issue highlighted the achievements in the field of Informatics, the science of information, the practice of information processing and the engineering of information systems, this issue of the Technorama is dedicated to Intelligent Motion Control Technology. This technology has emerged as a multidisciplinary technology covering multiple diverse technology disciplines such as, power semiconductor devices, power converter circuits, electrical machines, control theory applications, microelectronics including processors, and computer- aided design and simulation tools. Each component discipline has developed rapidly and provided a challenge to the research and development in the field of intelligent motion control technology. The contents of this issue by some of the experts in the field will vividly show us the application of this in various fields of science and technology. It will be an interesting and enjoyable experience for the reader to go through this issue.

A handwritten signature in black ink, appearing to read 'N R Bandyopadhyay'.

Prof N R Bandyopadhyay

On behalf of the Board of  
Consulting Editors

# TECHNORAMA

Volume 59 (T)  
March 2010

Contents

## Intelligent Motion Control and Power Electronics

3

Intelligent motion control technology with all its component disciplines is an exciting field of development and research. This article presents a multifaceted perspective on the commonality between motion control, power electronics, drives, mechatronics, and robotics and demonstrates that the advances of power electronics have enhanced the state-of-art of the motion control technology.

## High Performance Sensorless Velocity Servo System using IPM Synchronous Motors

13

This paper examines the accuracy and suitability of sensorless velocity estimation for application in a velocity servo system. Because of the magnetic saliency, interior permanent magnet motors have advantages of acting as their own position and velocity sensors, over other more conventional AC machines with uniform airgap. The elimination of the position/speed sensor is also desirable as it reduces the overall cost while increasing its reliability. Instead, the rotor speed and position are estimated from the measured stator currents and voltages. This paper provides an overview of these methods and highlights their strengths and weaknesses.

## TECHNORAMA

is a publication of  
The Institution of Engineers (India)

### President

Shri Madan Lal

### Board of Consulting Editors

Prof (Dr) Samiran Choudhuri  
Prof N R Bandyopadhyay  
Lt Gen (Dr) V J Sundaram

### Editor

Maj Gen (Retd) R K Sanan, VSM

### Associate Editors

Dr P Bose  
R Sridharan

### Special Contributors

S Chowdhury, S Chakraverty,  
K Sen, S Ghosh, S Das Gupta,  
T Biswas, Ms H Roy,  
K V Hariharan and S Bagchi

### The Institution of Engineers (India)

as a body accepts no responsibility  
for statements made by individuals.  
Reprints of any portion of the  
publication may be made provided  
that reference thereto be quoted.

### Publication Office

8 Gokhale Road, Kolkata 700 020  
Ph : 2223-8311/14-16/33-34  
Fax : (033) 2223-8345  
email : technical@ieindia.org  
web : http://www.ieindia.org

### Printer and Publisher

Maj Gen (Retd) R K Sanan, VSM  
for The Institution of Engineers (India)  
8 Gokhale Road, Kolkata 700 020

### Layout

S Bagchi

### Cover Design

S Bagchi and T Biswas

## Other Features

Science and Engineering :  
Chandrayaan-1 Experience

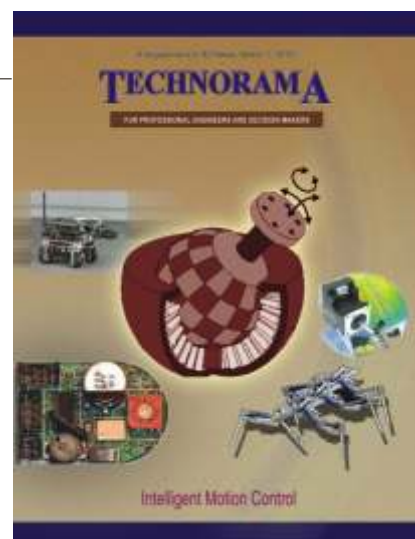
22

Tech News

28

Book Shelf

29



# Intelligent Motion Control

# Intelligent Motion Control and Power Electronics

**Prof Ajit K Chattopadhyay**

Honorary Emeritus Professor, Department of Electrical Engineering  
Bengal Engineering & Science University, Shibpur, Howrah 711 103

## INTRODUCTION

Motion control comprises every technology related to the movement of objects, small or big. Early motion control systems using mechanical gears and levers to select speeds and drive powers have long been replaced by electronic controllers, initially analog and then digital, which gave much more flexibility in speed control and ability to obtain systems with more complex movement. With the advent of power electronics (PE), motion control today encompasses a very wide spectrum of applications covering drives, actuators, mechatronics ( a term coined by the Japanese in 1971 to describe the combination of power electronics and microcontrollers in mechanical systems) and robotics. At one end of the spectrum, there are low power drives for instrument type controls , computer peripheral drives, in the middle the medium power drives for machine tools, paper and textile mills, and robot control applications and on the other extreme end it covers the large multi-megawatt power drives for blower fans, compressors, ship propulsion, cement mill and rolling mill type applications as well as mass transportation systems.

Since 1980s, a revolutionary progress has been made in the performance improvement of

motion control technology through their implementation with power electronics combined with mini- and microcomputers, microprocessors, DSP technology, ASICs and now, FPGAs. These devices have provided significant cost reductions in control electronics, reliability and flexible software control. Attempts are being also made to enhance and optimize the motion control performance further by intelligent, self-learning or self-organizing control utilizing artificial intelligence techniques like expert systems, fuzzy logic and neural network techniques with embedded protection and smart devices —thus emerging a new breed of intelligent motion control technology. This technology has emerged as interdisciplinary technology covering five major disciplines :

Power Electronics, Control Engineering, Computer Science, Sensor Technology and Mechanical Engineering, out of which the Power Electronics itself is a multidisciplinary technology embracing diverse technological disciplines such as : power semiconductor devices, power converter circuits, electrical machines and actuators, control theory applications, analog & digital electronics, microcomputers including signal processors, and computer-aided design and simulation tools (Figure 1). Each component discipline has developed rapidly and provided a challenge to the research and development in the field of intelligent motion control technology. Significant attention to motion control has been focused at

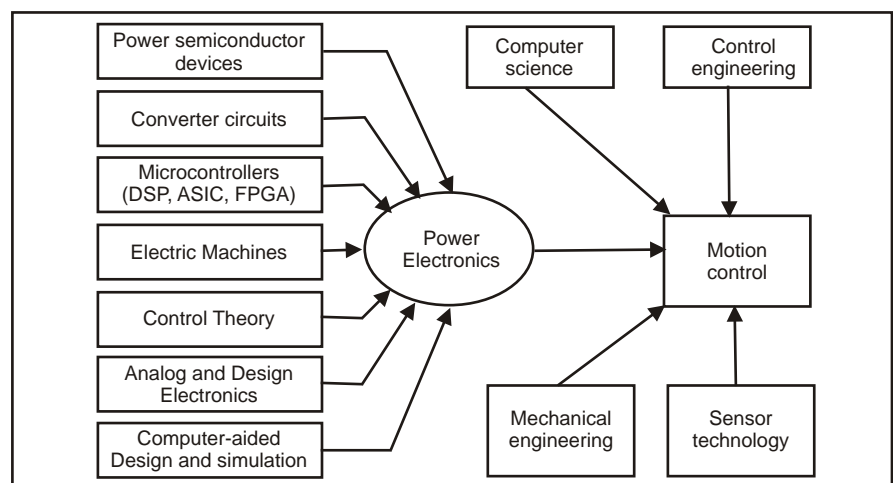


Figure 1 Motion control as an interdisciplinary technology

present to their applications related to computerized and automated factories and homes of the future.

Though power electronics essentially deals with processing electrical power with high efficiency, motion control has been developed by power electronics engineers through the application of control theory to power electronics to obtain complete control of motion such as in servo systems, machine drives and in robotic manipulators. In this article, we like to discuss the advances in motion control, particularly, in modern electrical drives and to some extent in mechatronics and robotics, as obtained, through the application of power electronics and advanced control techniques.

### MOTION CONTROL IN ELECTRICAL DRIVE SYSTEM

A typical modern electrical drive motion control system is shown in Figure 2 where the main components are: an electromagnetic machine or actuator (electromechanical energy converter), a power electronic electrical to electrical power converter with power semiconductor devices and an embedded digital controller. The digital controller directly controls the power electronic semiconductor switches of the converter with suitable controller software, hardware, sensors and processors.

### Power Semiconductor Devices

These devices (Figure 3), operating in switching mode, form the heart of a PE converter for motion control and they have followed the evolution of solid state electronics. Soon after the introduction of SCR (which turns on with a positive gate current pulse and turns off when anode current becomes negative), the seniormost device in the thyristor family in 1958 (which reigned supreme in medium and large power motion control for the next twenty years) by GE as a phase control device, other devices like small power GTO, Triac. Light activated SCR (LASCR), inverter type thyristors such as ASCR, RCT, GATT etc (now in obsolescence) were introduced in quick succession in 1960s. But real challenge to SCRs came after the emergence of high power self-commutating devices like high power GTOs, Power BJTs, Power MOSFETs, IGBTs in 1980s and now high power GTOs are being replaced by IGCTs and IEGTs since late 1990s. The modern light triggered phase control thyristors (LTTs) are available with ratings of 12 kV, 1.5 kA, developed mainly for HVDC and SVC applications as well as MW Cycloconverter-fed drives. The Triac which is an integral pair of SCRs connected in inverse parallel in the same chip has initial ratings of maximum 800V, 40 A but ABB

Silicon power DIODE (1955)	
Thyristor (SCR) (1958)	
TRIAC (1960)/BCT (Bi-directional control thyristor) (1998)	
Gate turn-off thyristor (GTO) (1960/1980)	
Bi-polar power transistor (BPT or BJT) (1975)	
Power mosfet (1978)	
Insulated gate bi-polar transistor (IGBT) (1983)	
Integrated gate-commutated thyristor (IGCT) (1996)	
Injection enhanced gate transistor (IEGT) (1999)	
Silicon carbide devices	

Figure 3 Development of power semiconductor devices

came out in 1998 with a Bidirectional Control Thyristor (BCT) with high ratings up to 6.6 kV, 3.5 kA. A GTO (a low power version invented by GE almost at the same time as the Triac in early sixties but reintroduced for high power applications, 6 kV, 6 kA, in Japan during early eighties) is a self-commutated thyristor device which can be turned on by a positive pulse and turned off by a large negative pulse (poor turn off gain, typically, 4 to 5). Because of high switching loss, a GTO converter is operated within 500Hz switching frequency. However, with development of lossless regenerative snubbers, the switching frequency and efficiency of the GTO converters could be improved. A BJT is a bipolar 2-junction 3-layer (PNP/NPN) transistor device which is current controlled through the base drive for on/off states. Its switching speed is considerably faster than the Thyristor type device but has characteristic second breakdown problem. The normal low current gain in a BJT can be enhanced in a Darlington Power Transistor which

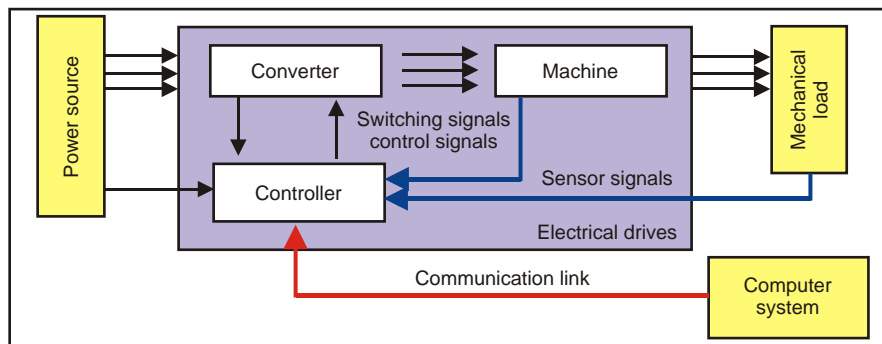


Figure 2 Block diagram of a typical modern electrical drive system for motion control [3]

is available in a modular form with matched devices up to 1200 V, 800 A. A power MOSFET is a unipolar, majority carrier, zero junction, voltage controlled device which requires very small driving power. It is one of the fastest power devices and can be operated in megahertz switching frequencies. It does not have a breakdown problem of BJT and the positive temperature coefficient of conduction resistance permits easy paralleling of these devices. However, the conduction losses are higher and so they are mainly used for low voltage low power high frequency switching applications such as SMPS, brushless dc (BLDC) motor drives etc. The state-of-the-art device available is 800 V, 50 A. Recent development of CoolMOS devices by Infineon is based on Super Junction design with much reduction in conduction loss.

The invention of the IGBT in 1983 by Baliga as a hybrid device combining the advantages of the MOSFET and BJT has been an important milestone in the history of power devices suitable for motion control. It has a high input impedance of a MOSFET but a BJT like conduction characteristics with improvement in conduction drop over that of MOSFET. It is turned off by zero gate voltage while turned on by +10 to +15 V at the gate. Its power rating is increasing continuously (currently up to 6.6kV, 700A) along with the improvement of electrical characteristics. Intelligent Power Electronic Modules (IPEM) are now available with built-in gate driver, control and protection to provide lower size and cost, improved reliability and less EMI problems for several high power ac motor drives.

High power (6.5 kV, 6 kA) IGCTs (or GCTs) have been introduced by ABB

since 1996 with unity current gain needing no snubbers and low switching loss to replace GTOs for the standard medium voltage drives like pumps, fans, compressors, conveyors and steel rolling mills with innovative control concepts like Direct torque control (DTC). They have higher switching frequency compared to GTOs. These are simple to use and they have demonstrated their reliability in many high power applications so far.

IEGT is an advanced high voltage high power IGBT with special gate construction developed by Toshiba in 1999 which exhibits low on-state voltage compared to IGBTs and GTOs even while rated at 4.5 kV, 5.5 kA. It does not need a turn-on or turn-off snubber like GTO. The gate power needed with this device is much less when compared to GTO or IGCT. IEGT based inverters of 8 MVA rating are now working in several rolling mill drives since 2000 with efficiency of 98.5%.

It has been possible to integrate the control (gate drive circuit) and power circuit on the same chip, defined as the smart power technology. This results in reduction of cost, size, EMI and improvement in reliability. A large family of power integrated circuits (PICs) that include power MOSFET smart switch, half bridge inverter, stepper-motor drive, one-quadrant chopper for dc motor drive, PWM inverter etc have become available. In the smart power control chip, the sensing and protection circuits have also been added. Application Specific Power Integrated Circuits (ASPICs) are also available.

So far, the PE devices have exclusively used silicon as the basic material. However, new materials,

such as, SiC (Silicon Carbide) and thin-film diamond show tremendous promise for future generation of devices. These materials are difficult to process but they provide the capability for much higher frequency, higher voltage, higher temperature, and lower conduction drop when compared to silicon devices.

### Power Electronic Converters

Various converter technologies, incorporating a matrix of power switching devices, have been evolved for conversion and control of electrical power under the guidance of control electronics. The general classification according to the function are: ac to dc (rectifiers), dc to dc (choppers), dc to ac (inverters), ac to ac (ac voltage regulators or cycloconverters) Converter evolution has followed the device evolution. The most common type of converter used is the Graetz bridge (initially developed with six diodes for 3-phase operation in 1897).

AC/DC converters or controlled rectifiers with thyristors use phase control and line commutation in 1-phase / 3-phase, semi- / full-bridge rectifiers for applications in dc motor drives, hvdc converters etc. The major problems with them are the generation of low order harmonics affecting the power quality and the supply power factor. Installing a diode rectifier at the front-end improves the harmonics and power factor considerably and the voltage regulation is done by a dc link chopper or PWM inverter using self-commutated devices (GTOs, BJTs, MOSFETs, IGBTs etc.).

DC/DC converters or choppers convert a constant dc voltage to a variable dc voltage or an unregulated to a regulated one and

are commonly used in dc motor drives and switching mode power supplies (SMPS). They can be traditional hard switching PWM type or soft switching resonant link type. Traditional PWM choppers can be buck (step down), boost (step-up) or buck-boost type. A single quadrant drive uses a buck converter, a two quadrant one buck and boost types in combination and a 4-quadrant drive uses an H-bridge providing buck and boost functions for either direction of rotation. High power converters use GTOs for traction drives whereas high frequency switching regulators use power MOSFETs or IGBTs. These converters have chopped input currents and so large ripples and harmonics. Simple transformer coupled flyback and forward dc-dc converter topologies are used in SMPS. In a resonant dc link inverter, the dc power is inverted to high frequency ac by a resonant circuit inverter and is then rectified to dc and passed through a low pass filter. The inverter devices are switched at zero voltage or zero current eliminating switching losses.

DC/AC converters or inverters are basically of two types: Voltage Source Inverter (VSI) and Current Source Inverter (CSI) and they are used for ac motor drives and many other applications, The VSI uses a diode rectifier and a capacitive filter at the front end and does not have inherent regenerative capability. Both sinusoidal PWM and hysteresis-band current controlled methods are widely used to regulate the voltage magnitude and harmonic ripple at the output. Several methods of PWM control, including the latest space vector modulation (SVM) technique and multilevel inverters have been introduced with GTOs, IGBTs,

IGCTs or IEGTs in a double-sided (dual) PWM VSI-fed rectifier-inverter high power drive for bidirectional power flow and sinusoidal current, both at the input and the output together with unity supply power factor. Figure 4 shows a diode-clamped type (also known as NPC) 3-level PWM GTO rectifier-inverter synchronous motor drive for rolling mills. In recent versions of these drive schemes IGCTs and IEGTs have replaced the GTOs. The CSI traditionally used thyristors with auto-sequential capacitive commutation for the inverter (ASCI) and thyristors in the front-end rectifier (without a capacitor filter but with a large series reactor) allowing a bi-directional power flow and regenerative capability. Later, the thyristors have been replaced by GTOs or IGCTs / IEGTs for both inverter and rectifier in a dual PWM CSI converter-inverter system resulting sinusoidal supply and machine side current and unity power factor. A CSI with a synchronous motor load can be easily commutated by the machine emf, the arrangement being popularly known as Load Commutated Inverter (LCI) drive which is commonly used in very large power applications, e.g., 100

MW NASA Wind Tunnel Drive . However, compared to CSI drive, PWM VSI drives are having increasing popularity.

AC/AC converters (Voltage Controllers / Cycloconverters / Matrix Converters): Thyristor or triac based ac/ac voltage controller at the same frequency use phase control for applications like lighting and heating control, domestic fans as well as for soft-starting induction motors. Thyristor-based phase-controlled cycloconverters are used in the VSCF (Variable Speed Constant Frequency) systems and very large ( megawatt) power low speed ac drives for cement and rolling mills as well as variable speed pumped storage system. The inherent problems are sub-harmonics, limited frequency range and lagging VAR. High pulse numbers, operation with fast current regulation and use of capacitor banks or SVC have been in practice to improve the power quality in such cases. Another class of frequency changers operating on PWM principle, known as Matrix Converter, using nine bidirectional switches, is receiving a lot of attention. These can directly generate a variable-frequency variable voltage supply for an ac

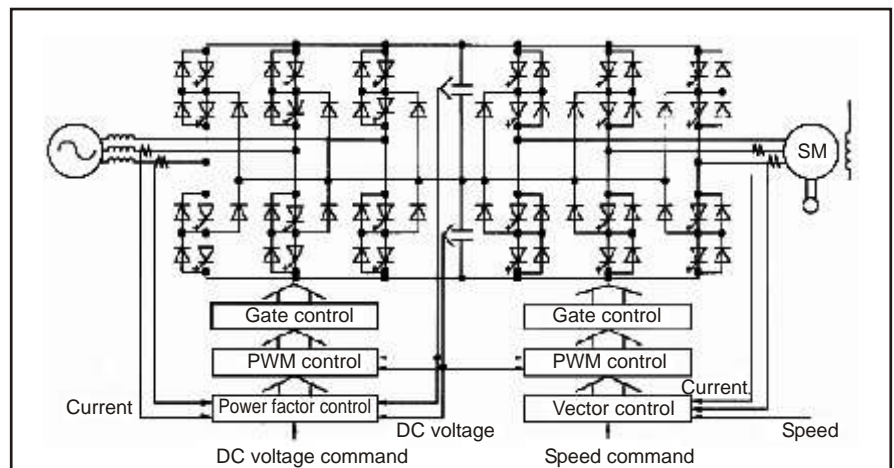


Figure 4 A 3-level GTO rectifier-inverter synchronous motor drive for rolling mills

motor drive with increased output frequency range and programmable input power factor. But the lack of suitable high frequency monolithic bidirectional switches and bulky input filters make the scheme uneconomical at present for large power.

### Electric Machines in Motion Control

Electric machines, the workhorses in motion control and, in particular, the dc, induction and synchronous types are with us for more than a century. The converter equipment and control principles are somewhat simple in the case of dc motors but the machine itself is more expensive and difficult to maintain in industrial motion control systems because of commutators and brushes. Ac motor drives, particularly, with rugged, more efficient and less expensive induction motors have evolved as the ideal adjustable speed drives through the use of variable frequency power electronic converters. Synchronous motors have become a close competitor as it can provide better power factor and less rotor copper loss. Intense research efforts have been made in the development of permanent magnet synchronous motors (PMSM), brushless dc motors (BLDCM) and switched reluctance motor (SRM) drives. Between the permanent magnet and wound rotor field synchronous machines, the latter is popular in multi-megawatt drive applications like rolling mills, ship drives, pumps and blowers etc. Linear synchronous machines (LSM) and linear induction machines (LIM) have been considered for high speed transportation. Self-controlled synchronous motors known as commutator-less motors when the

rotor position is fed back to generate the stator frequency with no risk of pulling out have become popular in high power high performance drives, specially, with vector control. The use of PMSM in self-controlled mode, known as brushless dc motors, are attractive for low power servo applications. The PMSM motors may be surface mounted type with salient pole structure with large air gap or non-salient pole structure having narrow air gap or interior (buried) magnet machines (IPM) which have narrow air gap and salient pole structure. (Figures 5a and 5b). Switched reluctance machines (SRM), shown in Figure 5c), a class of earlier known

variable reluctance machines, now converter-fed, have gained a lot of promise for low and medium power drives. The machine has saliencies in both stator and rotor with no rotor windings. Stator poles have concentrated windings, the currents in which are switched on and off in accordance with the rotor position to produce reluctance torque. The power converter requires fewer devices, which makes it simple and economical. The machine needs an absolute position sensor and has the drawback of pulsating torque and acoustic noise.

### AC Drive Control

Control of ac motor drives is more complex than that for the dc motor drives as the ac machine dynamics are more complex, intricate signal processing is needed and variable frequency supply is required. A simple, popular and economical but low performance control method for induction motor drive is the open loop V/Hz control (also known as scalar control) when a small drift in speed and airgap flux due to fluctuation of load torque or supply voltage, respectively, and sluggish transient response are of no consequence. Scalar speed or position feedback systems have inner flux, torque, slip and current control loops added where improved performance is needed.

For the highly coupled multivariable non-linear ac machine, the invention of vector or field-orientation control in Germany in 1971 and its implementation with micro-processors around early 1980s brought on a renaissance in high performance control of ac drive. This control technology has been widely accepted in applications like steel rolling mills, paper mills,

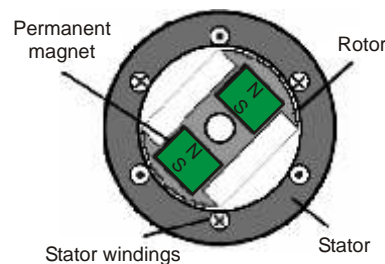


Figure 5(a) Permanent magnet synchronous machine

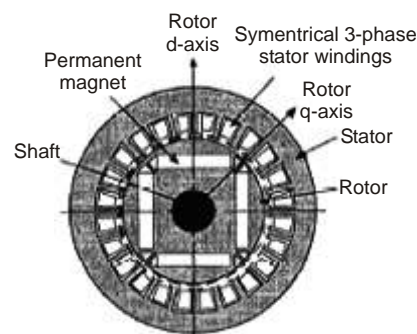


Figure 5(b) Interior or buried magnet (IPM) PMSM

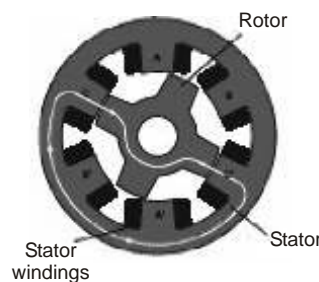


Figure 5(c) Switched reluctance machine (SRM)

textile mills, cement mills, machine tools, servos and robotics. With this control, the dynamics of ac drives is similar to that of dc drives, the flux and torque being decoupledly controlled by coordinate transformation. This control method can be direct as proposed by Blaschke which requires flux acquisition either by measurement or computation (from stator currents and speed signal) as shown in Figure 6(a) or indirect (or feed forward), Figure 6(b) as proposed by Hasse when the flux acquisition is avoided by computing the slip frequency to obtain the desired flux position. Rotor flux orientation

provides a perfect decoupled control. The indirect control scheme is popular as it is simple to implement. However, the motor parameters affect the decoupling and the performance. Considerable amount of research efforts have been directed towards developing parameter identification, self-commissioning and adaptation schemes for optimum decoupling in field orientation control. A universal vector control method has also been suggested where the indirect vector control operates in the lower speed range and the direct vector control takes over for higher speed range. Vector control has been applied to

both induction and synchronous motors fed from an inverter or a cycloconverter. For synchronous motor, a rotor position encoder is mandatory when the machine works as a brushless/commutatorless dc machine or electronically commutated machine where the inverter and position sensor carry out the functions of commutator and brushes of dc machine.

A new type of advanced computation intensive scalar control known as Direct Torque Control (DTC) as an alternative to vector control for a high performance drive proposed by Depenbrock in Germany and Takahashi in Japan around 1986 has been developed and marketed by ABB with IGBT-based high power inverter-fed drives. The advantages of this control are : simple direct control of torque and flux by selection of a voltage switch logic unit, no d/q axes or vector transformation, no traditional PWM algorithm, no feedback current control and no PI regulators. Here, the flux and torque are controlled through hysteresis type controllers and the PWM modulation is replaced by an optimal voltage vector (Figure 7a). The method results in better torque response than the field-orientation control and less static speed error even without a pulse encoder. DTC has been applied to induction motors, synchronous motors and even to SRMs. ABB has developed and marketed 3-level IGBT-based ACS 1000 (0.3-5 MVA) 3-level inverter with front-end rectifier employing DTC (Figure 7b) for pumps, compressors, conveyors etc. and ACS 6000 (3-27 MVA) with front-end controlled rectifier for plate mills/reversing cold rolling mills.

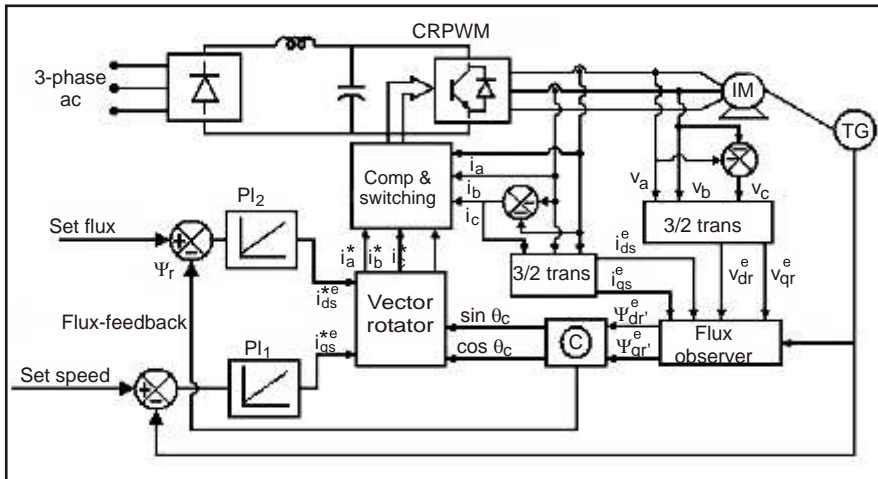


Figure 6(a) Direct vector control scheme for a CRPWM inverter-fed induction motor with a rotor flux observer (flux feedback)

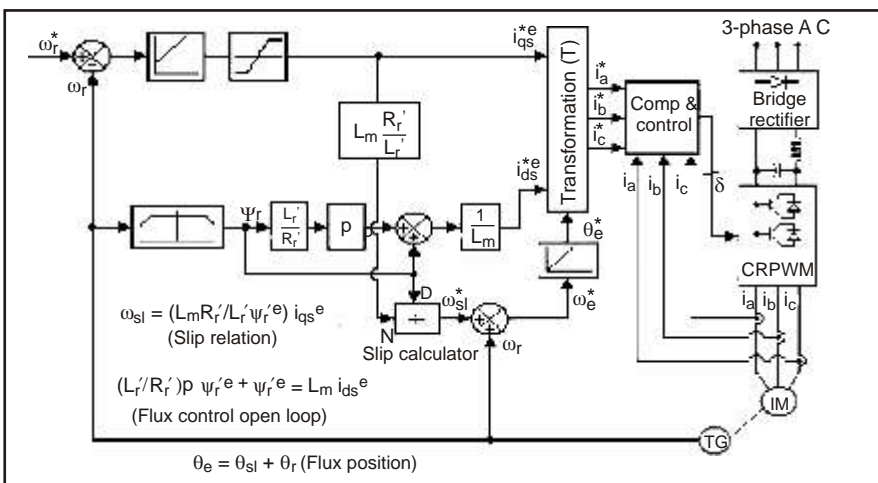


Figure 6(b) Rotor-flux oriented indirect vector control scheme for a CRPWM inverter-fed induction motor (flux feed forward)

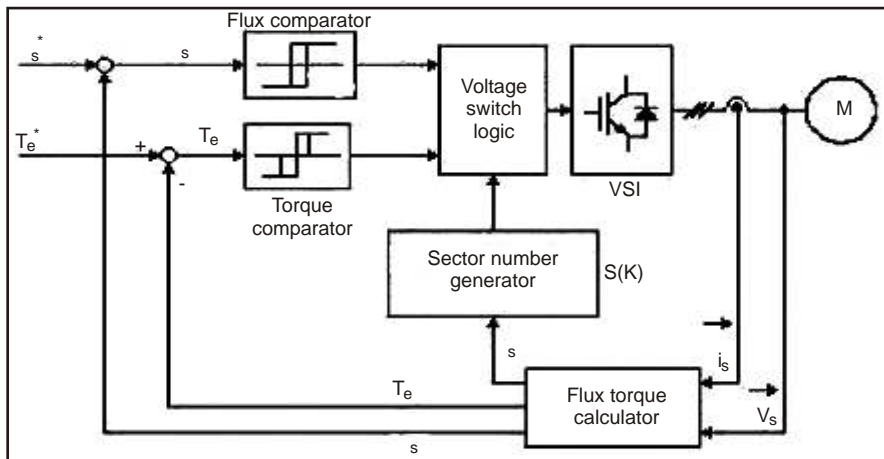


Figure 7(a) DTC block diagram

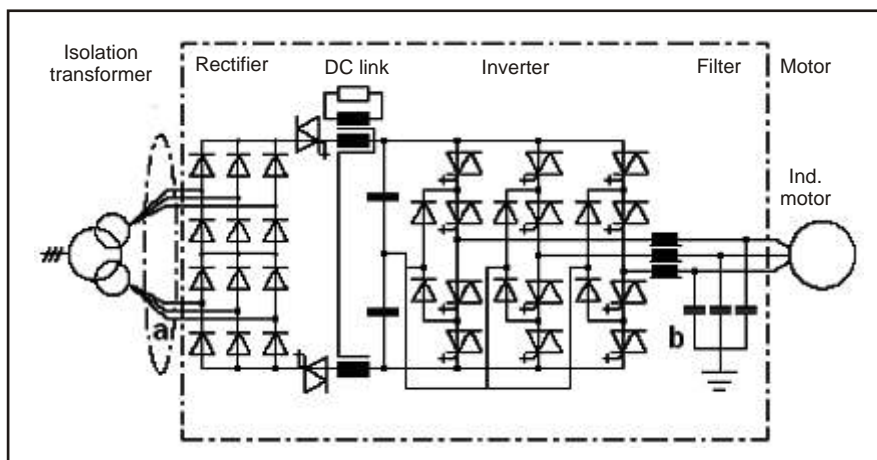


Figure 7(b) 3-level IGCT inverter with DTC (ACS 1000)

Sensorless drive control is comparatively a recent trend as the sensors add to the total cost of the drive and reduce the reliability. With measurement of stator currents and voltage, any other type of signal, such as, flux, torque, speed, position etc. can be estimated or observed with suitable algorithms in a microprocessor. Several such methods relating to induction motors, brushless PMSMs, SRMs have been compiled in an IEEE Press book<sup>10</sup>.

### Application of Modern Control Techniques

The conventional linear controllers such as PI and PID used in many drive applications are sensitive to plant parameter variations and load disturbances and it is difficult to

tune their gains both on-line and off-line. Recently, there has been a tremendous interest in applying modern optimal and adaptive control theories (like H-infinity, self-tuning, model referencing etc.) to ac drives due to the availability of powerful microprocessors and signal processors. In self-tuned adaptive control, the control parameters are tuned to adapt to the plant parameter variations. In model reference adaptive control (MRAC), the plant is forced to track the response of a reference model irrespective of plant parameter variation. A sliding mode or variable structure control technique, where the drive system is to follow a predetermined trajectory in the phase-plane irrespective of plant parameter variation has been

successfully applied to both induction and synchronous machine drives. It has become particularly popular in robust motion control applications. Optimal control theory, such as Pontryagin's minimum principle or dynamic programming techniques has been used in elevator movement between floors, transit car movement between stations with pre-computed control functions such as minimum time of transit or minimum energy consumption. Work has also been done in the application of state-variable feedback control with observers, considering the drive system as a multiple-input and multiple output system.

### Microcomputer Control Implementation

The advancement in microcomputers has substantially reduced the size and cost of the controllers for motion control, improved the performance and reliability, eliminated the drift and EMI problems and provided universal hardware and software flexibility. The complex computation and decision making capabilities of modern high speed computers with large functionality are permitting high performance real time controls as mentioned, state and parameter estimations, fault diagnosis and monitoring. High speed DSPs and Application specific ICs (ASICs), and now, field programmable gate arrays (FPGAs), well suited to work with modern PCs (Personal Computers), have revolutionized the field of motion control. Plug-and-play concepts are becoming a reality in control automation by integrating power, sensor wires, and communication links in a larger computer controlled environment.

**Intelligent Control with Expert, Fuzzy and Neural Network**

In general, it is very difficult for a motor drive system to follow the desired motion due to the existence of mutual dynamic interference among subsystems, external disturbances and system parameter variations. It is usually necessary to obtain knowledge of the control object (knowledge-based systems) in order to design controllers. To overcome these difficulties, an iterative learning control, which is one of the most important abilities of human beings, is introduced where the input of the present trial is modified by the error of the previous trial. In recent years, intelligent control based on expert systems, fuzzy logic and artificial neural network and genetic algorithm has found applications in drives and robotics applications. Expert system is a branch of artificial intelligence, a major discipline of computer science, by which a rule-based computer algorithm can be developed that mimics a human expert. This technique has been used in automated converter and system design and fault diagnostics. Fuzzy control, based on heuristics that are derived from the general behaviors of the process has been applied to

drives and motion control to develop adaptive controllers replacing the linear PI regulators as well as parameter estimation. Fuzzy control methods have been successfully applied both to large scale systems like cement kilns, subway train systems and on smaller scale in home appliances. Artificial neural networks are structures that emulate the biological process of human learning on a simplified scale have been used in PE systems to replace hysteresis-band current control in a PWM converter (Figure 8), Space Vector Modulation implementation, flux estimation etc.

**Simulation and CAD tools**

User-friendly simulation and computer-aided design (CAD) tools are finding increasing importance in motion control system design with a reduced engineering labour cost before building the breadboard. Various software tools like SPICE, SIMNON, EMTP, MATLAB / SIMULINK, SABER etc have been in use and many more are being introduced to model devices and systems. The PCs are playing an important role in making the use of these simulation and CAD tools (few developed by General Electric, Cambridge University etc).

**INTELLIGENT MOTION CONTROL IN MECHATRONICS AND ROBOTICS**

The mechatronics can be defined as the synergic integration of mechanical engineering with electronic and intelligent computer control in the design and manufacture of industrial products and processes. It includes the areas in modeling & design, manufacturing, system integration, motion control, actuators and sensors, vibration and noise control, intelligent control, robotics, mems, automotive systems etc. A lot of research work has been done in these areas and motion control is now recognized as a key technology in mechatronics. A schematic representation of relations of components of mechatronics is represented in Figure 9. A motion controller generates a set of inputs to the actuators according to a motion reference. A motion reference is synthesized in the reference generator. The sensor signal, the data base and the commands from other motion systems and /or human operators are input signals for the reference generator. The general motion control consists of the motion controller and the reference generator. The output of the motion is the position and / or force. The mechanical system is governed by the Lagrange equation for a dynamical system. The kinematics is represented as a set of algebraic equations which gives constraints of motion. It is necessary to track the motion reference accurately in the motion control part. The more intelligent a motion reference generator is, the more robust is the motion controller. This is a kind of master-slave structure. The actuator is in the form of a power electronic converter-based electric drive system with a suitable

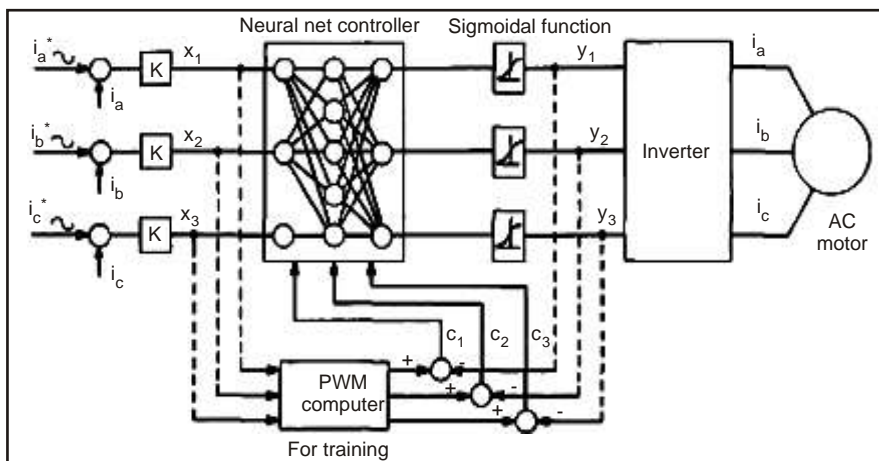


Figure 8 Neural network based PWM controller [11]

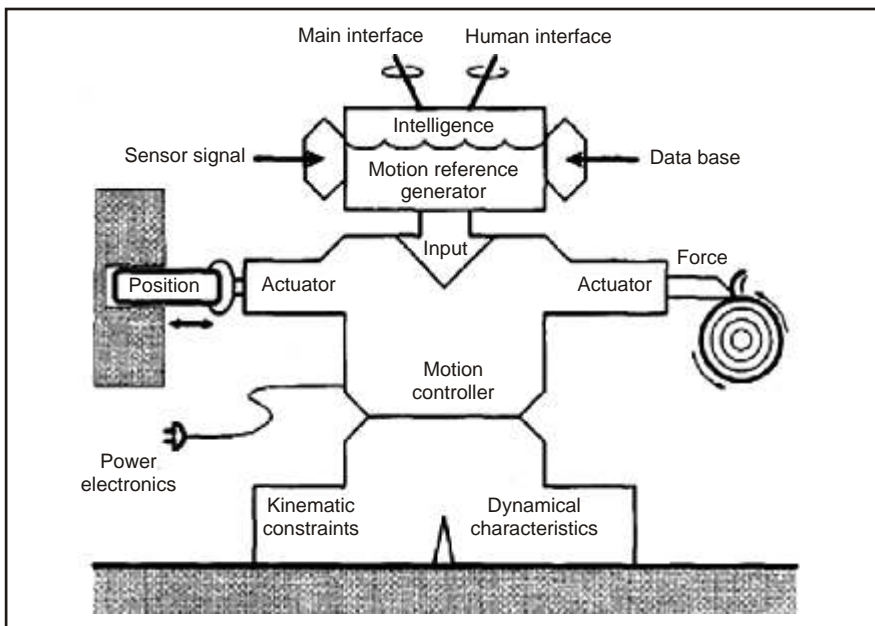


Figure 9 A schematic diagram of the components of intelligent mechatronics [12]

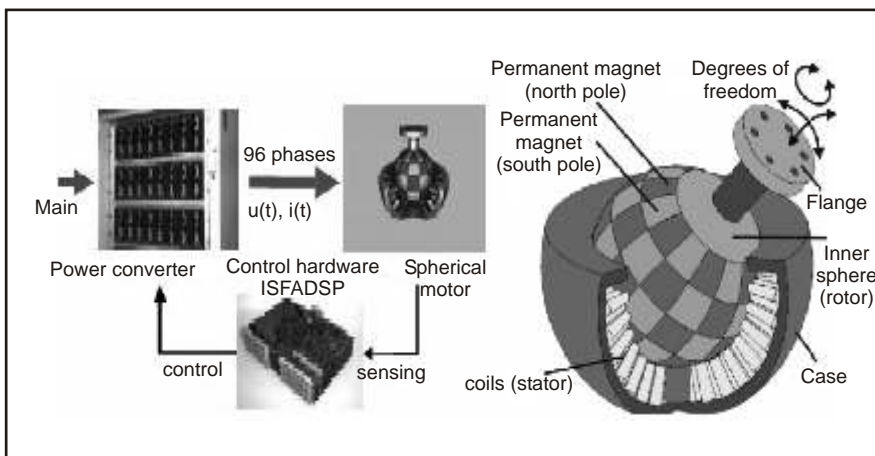


Figure 10 Spherical motor with 96-phase converter and control platform based on 6 DSPs [3] [15]

motor The power electronic converters use switching devices like MOSFETs, IGBTs etc for power control and the regulation of force / torque depends on the switching frequency. A current control feedback is used for torque control. An intelligence in the reference generator is key for intelligent mechatronics.

### Intelligent Control of Robots

Intelligence means the ability to comprehend, reason and learn and accordingly an intelligent control

system can be defined as a system which has the ability to comprehend, reason and learn about processes, disturbances, and operating conditions in order to optimize the performance of the processes under consideration. Robotic manipulators are complicated nonlinear systems modeled as a series chain of a number of moving rigid bodies. A set of highly coupled nonlinear differential equations can be derived to describe the relation between the torques applied at joints and the

positions, velocities and accelerations of joints. Intelligent control of robots have been through the application of learning control, use of knowledge base or an expert system, fuzzy logic control, neural networks and genetic algorithms. Several attempts have been made in combining these concepts like 'neuro-fuzzy' control to get more intelligent control.

An interesting application of a complex multi-axis direct drive spherical motor which may be used for robots and positioning equipment in machine tools is shown in Figure 10, where three degrees of angular freedom (classical yaw, pitch and roll) are incorporated. The stator consists of 96 stator poles and windings which have to be controlled individually. It is fed from a 96-phase power electronic converter which controls all the 96 poles so that the space varying flux linkages can be precisely controlled. Each phase is controlled using synchronized current regulators to avoid low frequency vibrations of the rotor. Six DSPs calculate the transformations and vector rotations such that each phase is under field oriented control. On the inner sphere, 112 NEFeB permanent magnets are mounted in seven rows each having 16 magnets in alternate north and south orientation.

Some technological advances in the automation and robotics applications of power electronics most directly affect the productivity of automation systems. For example a system consisting of a grid of high performance linear induction machine (LIM) has been proposed as material transporter where power electronics plays a major role.

### CONCLUSIONS

Intelligent motion control

technology with all its component disciplines is an exciting field of development and research. This article has presented a multifaceted perspective on the commonality between motion control, power electronics, drives, mechatronics, and robotics. It has been demonstrated that the advances of power electronics have enhanced the state-of-art of the motion control technology in the area of industrial drives, mechatronics and robotics. Developments in the field of intelligent control in the field of industrial drives and robots have already achieved promising results and with the fusion of information technology, communication network technology and power electronics will rise to greater heights in future.

#### REFERENCES

1. B K Bose. 'Motion Control Technology- Past, Present and Future'. *IEEE Trans. on Industry Applications*, vol IA-21, no 6, November/December 1985, pp 1337- 1342.
2. F Harashima. 'Power Electronics and Motion Control A Future Perspective'. *Proceedings of the IEEE*, vol 82, no 8, August 1994, pp 1107- 1110.
3. R W De Doncker. 'Modern Electrical Drives: Design and Future Trends'. *Proceedings of IEEE-IPERC Conf Rec.* August 2006, vol 1, pp 1-8.
4. B K Bose. 'Power Electronics and Motion Control Technology Status and Recent Trends'. *IEEE Trans. on Industry Applications*, vol 29, no 5, September/October 1993, pp. 902-909.
5. A K Chattopadhyay. 'Power Electronics Past, Present , and Future.' 7th P N Ghosh Memorial Lecture, *The Institution of Engineers (India)*, 26th December, 1997.
6. A K Chattopadhyay. 'Technological Advances in AC Drive Applications in the Steel Industry: - A Status Review'. *Presented at AITISM'09 Conference*, Ranchi 9-11 December, 2009.
7. B K Bose. 'Power Electronics and Motor Drives Advances and Trends'. Academic Press, 2006.
8. A K Chattopadhyay. 'Advances in Vector Control of ac Motor Drives - A Review'. *Sadhana (Jour. of Academy of Science)*, vol 22, pt 6, December, 1997, pp 797-820.
9. S Malik and D Kluge. 'ACS 1000- World's First Standard AC Drive for Medium Voltage Applications'. *ABB Review 2/1998*, pp 4-11.
10. K Rajasekhara, A Kawamura and K Matsuse, (Ed). 'Sensor-less Control of AC Motor Drives- Speed and Position Sensor-less Operation'. *IEEE Press*, New York, 1996.
11. B K Bose. 'Expert Systems, Fuzzy Logic, and Neural Network Applications in Power Electronics and Motion Control'. *Proc.IEEE*, vol 82, August 1994, pp 1303-1323.
12. K Ohnishi, M Shibata and T Murakami, " Motion Control for Advanced Mechatronics", *IEEE / ASME transactions on Mechatronics*, vol.1, no.1, March 1996, pp 56-67.
13. F Harashima. 'Intelligent Mechatronics'. *IEEE-AMC-1996*, pp15-17.
14. N K Sinha. 'Intelligent Control of Robots: Status and Future Perspectives'. *Proc. IEEE-TENCON*, 1998, pp 145- 152.
15. R D Lorenz. 'Robotics and Automation Applications of Drives and Converters'. *Proc IEEE*, vol 89, no 6, June 2001, pp 951- 960.
16. K Kahlen, I Voss and R W De Doncker. 'Torque Control of a Spherical Machine with Variable Pole Pitch'. *IEEE Trans. on Power Electronics*, vol 19, no 6, 2004, pp 1628- 1634.

# High Performance Sensorless Velocity Servo System using IPM Synchronous Motors

**G Foo**

*PhD Student, School of Electrical Engineering and Telecommunication, University of New South Wales, Australia*

**Dr M F Rahman,**

*Head, Energy Research Group, School of Electrical Engineering and Telecommunication, University of New South Wales, Australia*

This paper examines the accuracy and suitability of sensorless velocity estimation for application in a velocity servo system. Because of the magnetic saliency, the interior permanent magnet (IPM) motors have advantages of acting as their own position and velocity sensors, of course via estimators, over other more conventional AC machines with uniform airgap. The elimination of the position/speed sensor is also desirable as it reduces the overall cost while increasing its reliability. Instead, the rotor speed and position are estimated from the measured stator currents and voltages. Existing solutions can be broadly classified into open and closed-loop estimators and signal injection methods, exploiting the saliency property of the IPM motor. This paper provides an overview of these methods and highlights their strengths and weaknesses. Simulation and experimental results are included to supplement the discussion of this topic.

**Keywords :** Adaptive observer; Direct torque and flux control; Interior permanent magnet synchronous motors; Sensorless control; Signal injection; Velocity servo system

## INTRODUCTION

High performance velocity servo systems using interior permanent magnet (IPM) synchronous motors without speed sensors has been explored over the past decade. The absence of the mechanical encoder presents reduced hardware complexity and lower overall cost with improved system reliability. Furthermore, there are cost sensitive applications such as appliance drives or in a hostile environment where by the mechanical encoder is not favourable. Using control theory, the rotor position and speed can be estimated from the measured stator currents and voltages.

The proposed algorithms for sensorless speed control of IPM motors can be summarized as.

- Open-loop back-emf based estimators<sup>1-3</sup>.
- Closed-loop observers based on advanced models<sup>4-13</sup>.
- Estimation based on high

frequency signal injection<sup>14-18</sup>.

The first two categories utilize the mathematical model of the IPM motor. A sinusoidal air-gap flux density is assumed, neglecting the spatial harmonics and their effects. The former is derived through the integration of the back-emf of the machine without any correction term while the latter makes use of the error between the estimated and measured quantities as feedback to increase their performance. In any case, these methods have their limitations in the very low speed region due to reasons that will be discussed later. These problems exist regardless of the applied control methodology — field oriented control (FOC)<sup>19</sup> or direct torque and flux control (DTFC)<sup>20</sup>.

On the other hand, the signal injection method exploits anisotropy due the saliency of the IPM machine (or magnetic saturation of the surface PM machine). A high frequency test

signal is superimposed onto the fundamental control voltage and the rotor position information is detected from the current responses. This method provides a solution at standstill and very low speeds. Nevertheless, as the speed increases, the rotor position sensing accuracy falls and this leads to deterioration of performance.

This survey paper attempts to provide an overview of these algorithms. The DTFC scheme is briefly reviewed first as it is used extensively throughout the paper. Then, descriptions of each speed observer approach are provided together with its merits and shortcomings. Simulation and experimental results are integrated into the discussion to further demonstrate the performance of each method.

## DIRECT TORQUE AND FLUX CONTROL

In the stator flux ( $x$ - $y$ ) reference frame, the IPM machine can be

mathematically expressed as follows.

$$\left. \begin{aligned} v_x &= R_s i_x + \frac{d\lambda_x}{dt} = R_s i_x + \frac{d|\lambda_s| \cos \theta}{dt} \\ v_y &= R_s i_y + \frac{d\lambda_y}{dt} = R_s i_y + \frac{2R_s}{3P|\lambda_s|} T + \frac{d|\lambda_s| \sin \theta}{dt} \end{aligned} \right\} (1)$$

where  $v_x, v_y$ , stator voltage in the  $x$ - $y$  reference frame ;  $i_x, i_y$ , stator current in the  $x$ - $y$  reference frame ;  $|\lambda_s|$ , stator flux linkage amplitude ;  $R_s$ , stator resistance ;  $\omega_s$ , speed of stator flux linkage vector ;  $T$ , electromagnetic torque ; and  $P$  and number of pole pairs

Equation (1) shows that the stator flux can be directly regulated by the  $x$ -component of the stator voltage. In addition, provided that the amplitude of the stator flux is constant, the  $y$ -component of the stator voltage is qualified to regulate the torque of the machine. This serves as the basis of the DTFC scheme for IPM motors as illustrated in Figure 1.

The DTFC controller consists of two PI regulators one for flux and one for torque. The inputs of the PI controllers are the torque and flux errors while the outputs are the  $x$ - $y$  reference voltage vector. The reference voltage vector is transformed to the stationary frame and synthesized using the space vector modulation (SVM) algorithm. This control strategy is very effective

in minimizing the torque and flux ripples.

The dynamic responses of the stator flux linkage and electromagnetic torque under DTFC were evaluated in experiments. In Figure 2, the stator flux reference was stepped from 0.55 Wb to 0.65 Wb while rated torque dynamics was performed in Figure 3. The results infer that the DTFC is capable of delivering fast transients with minimized torque and flux ripples.

Since the actual flux and torque are not measurable in a practical drive, these variables have to be estimated instead. An alternative is to use a mechanical encoder but that option is not attractive. Therefore, torque, flux and speed observers have to be used instead. The remaining sections of this paper are devoted to the discussion of these observers.

**OPEN-LOOP ESTIMATORS**

The stator flux linkage can be found by integrating the back-emf of the machine<sup>1</sup>.

$$\left. \begin{aligned} \hat{\lambda}_x &= \int (v_x - R_s i_x) dt \\ \hat{\lambda}_y &= \int (v_y - R_s i_y) dt \end{aligned} \right\} (2)$$

where,  $v_x, v_y$ , stator voltage in the  $x$ - $y$  reference frame ;  $i_x, i_y$ , stator current in the  $x$ - $y$  reference frame ;  $\lambda_x, \lambda_y$ , stator flux linkage in the  $x$ - $y$  reference frame ; and  $\hat{\lambda}_x, \hat{\lambda}_y$  denotes estimated quantities. The stator flux

angle can be calculated by

$$\hat{\theta}_s = \tan^{-1} \left( \frac{\hat{\lambda}_y}{\hat{\lambda}_x} \right) \quad (3)$$

The rotor speed  $\omega_{re}$  is then be estimated from<sup>21</sup>

$$\hat{\omega}_{re} = \frac{d\hat{\theta}_s}{dt} \quad (4)$$

A low-pass filter is used to remove the noise from the speed signal. The block diagram of the open-loop estimator is depicted in Figure 4. This estimator has the advantage of being simple. Nevertheless, the pure integration is difficult to apply in practice due to the following reasons.

**DC-measurement Offset**

In practice, the currents and voltages of the machine are obtained using Hall sensors and operational amplifiers. DC-measurement offset due to op-amp non-idealities are inevitable and they change

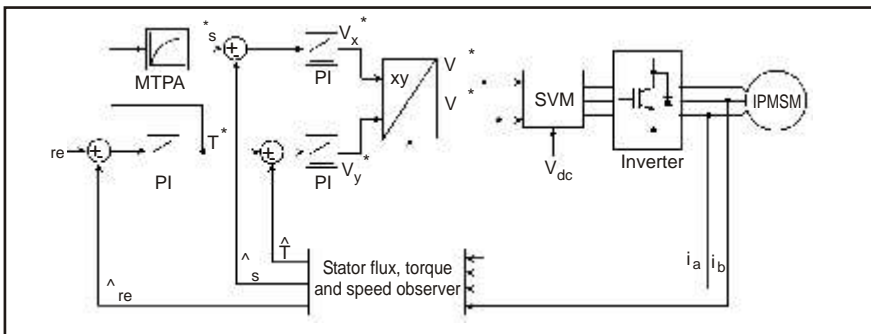


Figure 1 Block diagram of the DTFC scheme for the sensorless velocity servo system of IPM synchronous motor

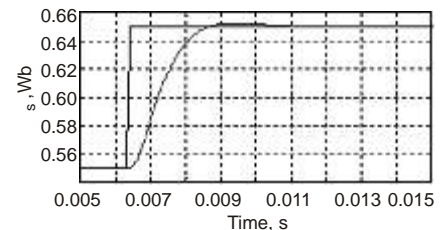


Figure 2 Flux dynamic response (experiment)

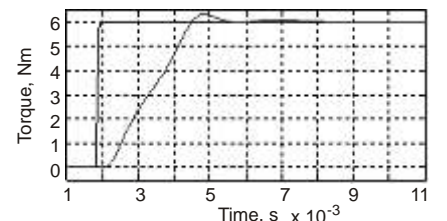


Figure 3 Torque dynamic response (experiment)

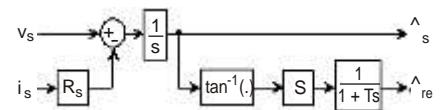


Figure 4 Block diagram of the open-loop estimator

according to thermal conditions. As a consequence, these offset get accumulated at the integrator output and the flux estimate drift out of bounds. The estimator fails even if a minute dc-offset is present in either the voltage or current channel.

This problem can be alleviated by substituting the pure integrator with a low-pass filter whose cut-off frequency is  $\omega_c$ . The block diagram of the improved estimator is shown in Figure 5. Unlike a pure integrator, the low-pass filter limits the effect of the dc-offset gain  $k$  within reasonable limits at the expense of its frequency response. From the bode diagrams in Figure 6, it can be observed that the low-pass filter mimics the integrator if the operating frequency,  $\omega \gg 1/\tau$ . On the other hand, the gain and the  $-90^\circ$  phase shift of the integrator are lost as the frequencies reduces. This causes erroneous error in the flux estimation and the stability of the drive will be compromised.

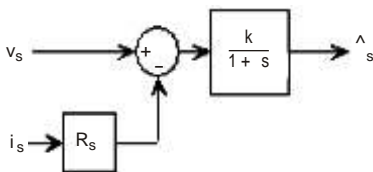


Figure 5 Block diagram of the improved open-loop flux estimator

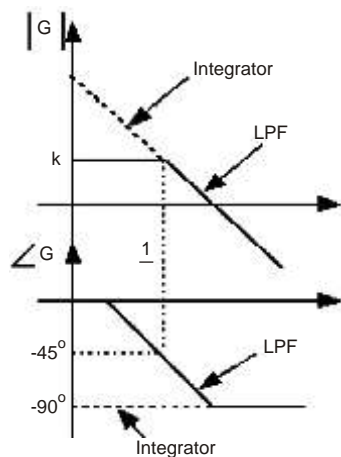


Figure 6 Bode diagram of the integrator and improved open-loop flux estimator

### Stator Resistance Variation

In reality, the stator resistance varies according to change in operating temperature. As a result, the flux estimator may produce errors if the stator resistance is regarded as a constant parameter in equation (2). At high speeds, the effect of stator resistance variation is negligible since the machine back emf is dominant. On the other hand, at lower speeds (usually  $\omega_{re} < 100$  rpm), the stator resistance drop is comparable to the back emf and hence, significant changes in stator resistance can easily lead to instability.

Therefore, a resistance estimator is mandatory if satisfactory performance is desired at low speeds. An online resistance estimator based on torque estimation error was proposed in<sup>21</sup> but the knowledge of  $dq$ -axes inductances which also change according to operating conditions is required in this scheme.

### Inverter Nonlinearities

The voltage signal used in equation (2) is usually reconstructed from the dc-bus voltage and switching states of the voltage source inverter (VSI). Unfortunately, this is hardly the actual voltage seen at the terminals of the machine due to forward voltage drops and dead-time effects of the inverter. This contributes to flux estimation errors. Again, this deviation in the voltage signal is negligible if the operating speed is sufficiently high but becomes severe as the speed decreases due to reasons mentioned earlier. Several compensation methods of dead-time and forward voltage drops of the inverter have been proposed. A software-based compensation scheme was described by Choi and

Sul<sup>22</sup>. Its main disadvantage is that it requires the on-state voltage, turn-on and turn-off times of the power switches to operate successfully. These parameters also change to operating conditions and this may affect the effectiveness of this scheme. This problem can be circumvented by implementing hardware-based compensators as in Holtz and Quan<sup>23-24</sup> at the expense of additional cost and complexity. Figures 7 and 8 illustrate the torque and flux estimation errors at 50 rpm due to inverter nonlinearities effects with and without compensation respectively.

### CLOSED-LOOP OBSERVERS

Although explicit compensation is incorporated into the estimator, there exists a lower operating speed limit of the sensorless drive. Needless to say, the limit of

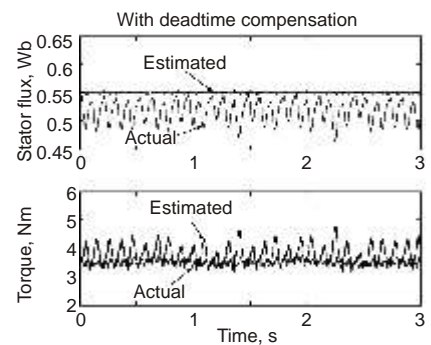


Figure 7 Stator flux and torque estimation errors due to inverter nonlinearities effects at 50 rpm without compensation (experiment)

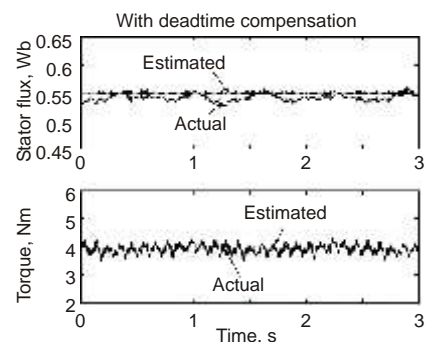


Figure 8 Stator flux and torque estimation errors due to inverter nonlinearities effects at 50 rpm with compensation (experiment)

acceptable performance depends on how precisely the model parameters matches the actual machine. An alternative is to use some sort of correction scheme. Closed-loop observers employing current estimation errors as feedback display robustness to parameter variations and improved dynamics responses.

**Speed Adaptive Observers**

Speed adaptive observers can be realized in either the stationary ( )<sup>4-6</sup> or rotating (dq)<sup>7-8</sup> reference frame. For example, by assuming rotor orientation, the speed adaptive flux observer can be designed as

$$\begin{aligned} \begin{pmatrix} \dot{\hat{d}} \\ \dot{\hat{q}} \end{pmatrix} &= \begin{pmatrix} -\frac{R_s}{L_d} & -\frac{L_d}{L_q} \hat{\omega}_{re} \\ -\frac{L_d}{L_q} \hat{\omega}_{re} & -\frac{R_s}{L_d} \end{pmatrix} \begin{pmatrix} \hat{d} \\ \hat{q} \end{pmatrix} \\ &+ \begin{pmatrix} v_d \\ v_q \end{pmatrix} + \begin{pmatrix} \frac{R_s}{L_d} f \\ 0 \end{pmatrix} + K S \\ &+ \text{sign}(S) \\ \begin{pmatrix} \dot{i}_d \\ \dot{i}_q \end{pmatrix} &= \begin{pmatrix} \frac{1}{L_d} & 0 \\ 0 & \frac{1}{L_q} \end{pmatrix} \begin{pmatrix} \hat{d} \\ \hat{q} \end{pmatrix} - \begin{pmatrix} f \\ 0 \end{pmatrix} \end{aligned} \quad (5)$$

where,  $v_d, v_q$ , stator voltage in the  $d$ - $q$  reference frame ;  $i_d, i_q$ , stator current in the  $d$ - $q$  reference frame ;  $\hat{d}, \hat{q}$ , stator flux linkage in the  $d$ - $q$  reference frame ;  $L_d, L_q$  the  $d$ - $q$ -axes inductances ;  $f$ , permanent magnet flux linkage ; and  $K$  and  $\text{sign}$  are gains of the observer.

The observer uses both linear and nonlinear feedback terms. The sliding hyperplane is defined upon the stator current estimation errors,

$$S = \begin{pmatrix} S_1 \\ S_2 \end{pmatrix} = \begin{pmatrix} i_d - \hat{i}_d \\ i_q - \hat{i}_q \end{pmatrix} = 0 \quad (6)$$

Global asymptotic stability of this observer can be proven via the

Lyapunov stability analysis in Foo and Rahaman<sup>25</sup>. The linear gain  $K$  can be designed based on the pole placement approach. Traditionally, the observer poles are selected to be proportional to the motor poles<sup>26</sup>. This approach allows the observer to be dynamically faster than the motor but is susceptible to noise. This problem can be circumvented by designing the observer poles with identical imaginary parts as the motor poles, but shifted to the left in the complex plane<sup>27</sup>. Whilst still possessing faster dynamics, the noise immunity of the observer is improved because the other pole, already having a large magnitude is less amplified<sup>28</sup>. The sliding mode gain  $\text{sign}$  is responsible for the robustness of the observer. Larger gain values increase the robustness of the observer but may generate unwanted chattering.

The estimated speed is required to adapt the observer to the actual rotor speed. It can be shown that the following adaptation laws suffice.

$$\dot{\hat{\omega}}_{re} = (\hat{q} \tilde{i}_d - \hat{d} \tilde{i}_q) dt \quad (7)$$

where  $\gamma > 0$ . Instead of pure proportional gains, PI type gains are used to improve the dynamics of the adaptation scheme in equation (7). Figure 9 shows the block diagram of the observer defined in equation (5). In general, speed adaptive observers deliver better performance than the open-loop integrator but are still susceptible to effects to dc-offset and inverter nonlinearities. Furthermore, due to its speed adaptive nature, its low speed performance is also limited. In digital realization of the observer, the speed adaptation is usually performed as the last step of the estimation process. Hence, the speed estimate is affected by cumulative errors, noise and

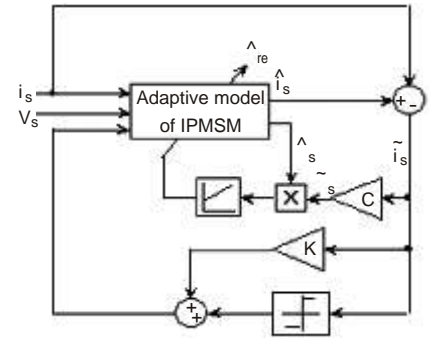


Figure 9 Block diagram of the adaptive observer in equation (5)

delays<sup>29</sup>. When the inaccurate speed value is fed back to the observer, the flux and speed estimation gradually worsen. This can easily lead the drive to instability especially at low speeds. An alternative is to adopt the speed non-adaptive observer elaborated in the succeeding section.

**Speed Non-adaptive Observers**

Speed adaptive observers are always realized in a single reference frame which results in a rotor speed dependant term. As a result, the observer has to be speed adaptive. On the contrary, the speed non-adaptive observer employs both the stationary ( ) and rotating (dq) reference frames and can be expressed mathematically as

$$\begin{aligned} \frac{d}{dt} \begin{pmatrix} \hat{d} \\ \hat{q} \end{pmatrix} &= -\hat{R}_s \begin{pmatrix} \hat{d} \\ \hat{q} \end{pmatrix} + \begin{pmatrix} v_d \\ v_q \end{pmatrix} + K \begin{pmatrix} i_d - \hat{i}_d \\ i_q - \hat{i}_q \end{pmatrix} \\ &+ \text{sign} \begin{pmatrix} i_d - \hat{i}_d \\ i_q - \hat{i}_q \end{pmatrix} \\ \begin{pmatrix} \dot{\hat{d}} \\ \dot{\hat{q}} \end{pmatrix} &= T^{-1}(\hat{q}_{re}) \begin{pmatrix} \frac{1}{L_d} & 0 \\ 0 & \frac{1}{L_q} \end{pmatrix} T(\hat{q}_{re}) \begin{pmatrix} \hat{d} \\ \hat{q} \end{pmatrix} \\ &+ \frac{f}{L_d} \begin{pmatrix} \cos \hat{q}_{re} \\ -\sin \hat{q}_{re} \end{pmatrix} \end{aligned} \quad (8)$$

where  $T(\hat{\theta}_{re}) = \begin{pmatrix} \cos \hat{\theta}_{re} & -\sin \hat{\theta}_{re} \\ \sin \hat{\theta}_{re} & \cos \hat{\theta}_{re} \end{pmatrix}$ ,  $K$  and  $\text{sign}$  are the gains of the observer. Akin to its adaptive

counterpart, this observer employs both linear and nonlinear feedback terms. The estimated rotor angle is calculated from

$$\hat{\theta}_{r,\alpha} = \tan^{-1} \left( -\frac{\hat{\lambda}_{\alpha,\beta}}{\hat{\lambda}_{\alpha,\alpha}} \right) \quad (9)$$

where

$$\left. \begin{aligned} \hat{\lambda}_{\alpha,\alpha} &= \hat{\lambda}_\alpha - L_\sigma i_{\alpha} \\ \hat{\lambda}_{\alpha,\beta} &= \hat{\lambda}_\beta - L_\sigma i_{\beta} \end{aligned} \right\} \quad (10)$$

is called the active flux<sup>30-32</sup> or extended rotor flux<sup>33</sup>. The block diagram of the observer is depicted in Figure 10. The observer employs two reference frames both the stationary ( ) and rotor (*dq*) frames. The state equation implements the voltage model in the stationary ( ) frame to estimate the stator flux. The active flux and estimated rotor position are calculated based on (9) and (10). Assuming orientation, the output equation of the observer estimates the current using the *dq*-axes current model.

The current estimation errors are then used as feedback signals for correction. The stator flux observer combines the advantages of the current model at low speeds and that of the voltage model at higher speeds.

Note that the rotor speed term is absent from the observer model due to the two reference frames. Consequently, unlike conventional speed adaptive observers, any error

associated with inaccurate speed estimation is eliminated, hence improving the stator flux estimation at very low speeds. The observer gains can be found from the procedure outlined earlier.

The performance of this observer relies heavily on the stator resistance parameter. Any mismatch may severely affect the operation of the drive. Figure 11 illustrates the torque and stator flux estimation errors in simulation due to +20% variation in  $R_S$  when the machine is running at 300 rpm. Rated load was applied at  $t = 1$  s. The drive is stable but the estimation errors are significant. To mitigate the undesirable effects of stator resistance variations on the sensorless drive, an online resistance estimator can be incorporated.

$$\hat{R}_s = - \int (i \tilde{i} + i \tilde{i}) dt \quad (11)$$

Figure 12 illustrates the estimation algorithm due to 20% increase in when the machine is running at 50 rpm. Half-rated load was applied to the motor shaft. The stator resistance estimator is very effective even at this low speed as it is able to identify the actual stator resistance value within a short time-frame.

Another critical problem of the low speed operation of the flux observer is the dc-measurement offset. Figure 13 shows the torque and flux estimation errors due to a 0.5V offset

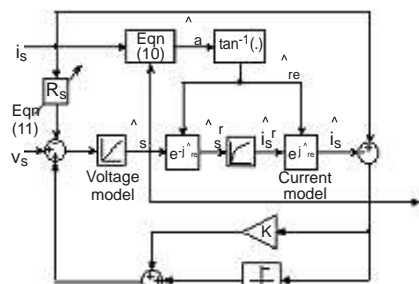


Figure 10 Block diagram of the speed non-adaptive observer

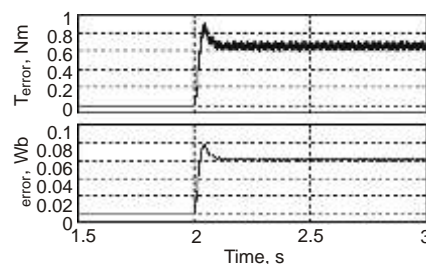


Figure 11 Torque and flux estimation error due to +20% variation in stator resistance at 300 rpm (simulation)

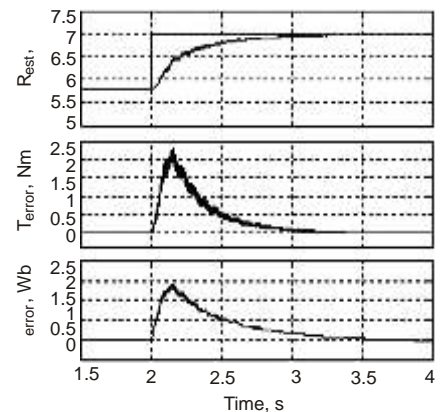


Figure 12 Stator resistance estimation and the corresponding torque and flux estimation errors due to 20% increase in resistance at 50 rpm (simulation)

voltage in both  $v$  ,  $v$  channels in simulation. The machine was initially accelerated from standstill to 1000 rpm. At  $t = 1$  s, rated torque was applied to the shaft of the motor. At  $t = 1$  s, the machine was decelerated to 40 rpm. From Figure 13, it is obvious that the high speed performance is marginally affected but the low speed performance is ruined.

The effects of the dc-offset can be alleviated by introducing an integral component in the observer gain as

$$K = (k_1 + \frac{k_I}{s})I + k_2J \quad (12)$$

where  $k_I$  is a small positive gain.  $k_I$  0.5 is practical for a real drive. Figure 14 shows the torque and flux estimation errors with the same dc-offset voltage and test conditions as before but with observer gains in equation (12). The errors at low

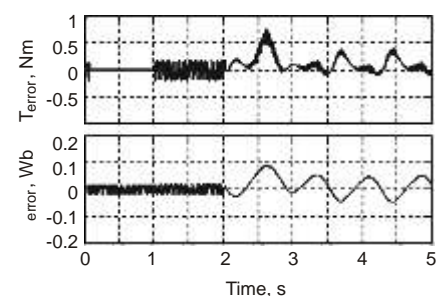


Figure 13 Torque and flux estimation error due to 0.5 V dc-offset voltage (simulation)

speed are now eliminated, proving the effectiveness of the dc-offset compensation.

The rotor speed is only required for speed control. It can be calculated based on the derivative of equation (9).

$$\hat{\omega}_{re} = \frac{\hat{\lambda}_{a,\beta}(k) - \hat{\lambda}_{a,\beta}(k-1) - \hat{\lambda}_{a,\beta}(k-1) \hat{\lambda}_{a,\beta}(k)}{T_s (\hat{\lambda}_{a,\beta}(k) + \hat{\lambda}_{a,\beta}(k))} \quad (13)$$

where  $T_s$  is the sampling period and  $k$  and  $k-1$  denote two consecutive sampling instants. The speed signal is low-pass filtered to remove the noise. This is a compact yet effective speed estimation scheme.

Experimental results of steady-state operation at 5 rpm with full-load are shown in Figure 15. The estimated and actual speeds, estimated torque and flux and speed estimation error are shown. From Figure 15, we can observe that the observer is capable of full-load operation at standstill and the average speed estimation error is zero.

The low-speed reversal from -10 rpm to +10 rpm with full-load is depicted in Figure 16. The same quantities are shown. The estimated speed follows the actual speed very closely during the transient interval. The dynamic response during acceleration from standstill to 1000 rpm is shown in Figure 17. The machine was originally operated at zero speed with no-load and was

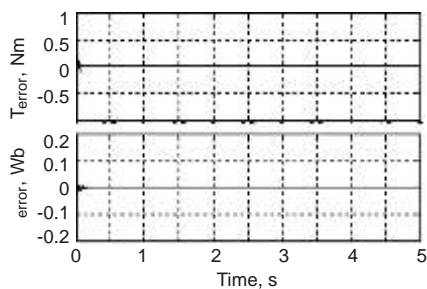


Figure 14 Torque and flux estimation error due to 0.5V dc-offset voltage and offset compensation gain (simulation)

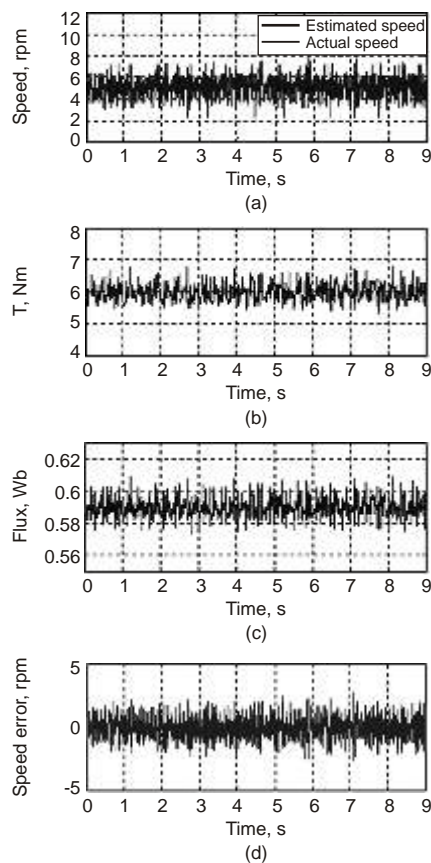


Figure 15 Sensorless full-load operation at 5 rpm (a) actual and estimated speeds, (b) estimated torque, (c) estimated flux, (d) speed estimation error (experimental)

accelerated to 1000 rpm at  $t = 0.3s$ . The estimated speed tracks the actual speed closely during the transient and steady-state.

Although temporary standstill operation with full-load is possible with this observer, it should be noted that permanent stability at zero-speed cannot be guaranteed. If the dc-offset changes at standstill, the compensation scheme in equation (12) fails as it cannot distinguish the offset from the actual signal. It was found in experiments that the lowest possible speed with stable operation is approximately 2 rpm. If persistent full-load operation at standstill is required, signal injection methods must be explored.

### HF SIGNAL INJECTION

Several high frequency (HF) hods

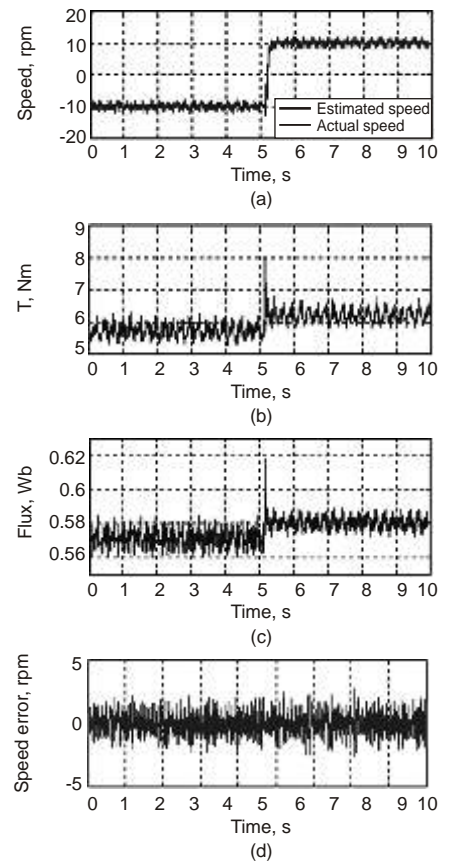


Figure 16 Full-load speed reversal from -10 rpm to +10 rpm (a) actual and estimated speeds, (b) estimated torque, (c) estimated flux, (d) speed estimation error (experiment)

injection methods can be found in the literature. These methods can be classified into - reference frame rotating injection<sup>14</sup>,  $d-q$  reference frame pulsating injection<sup>15</sup> and  $d-q$  reference frame rotating injection<sup>16</sup>. In this paper, the  $d-q$  reference frame persistent HF rotating carrier injection is discussed, where an alternating voltage is used for injection. A carrier excitation signal fluctuating at angular frequency  $\omega_c$  and having amplitude  $V_c$ , as shown in equation (14), is superimposed on the  $d$ -component of the stator voltage in the estimated rotor reference frame.

$$V_{hf} = V_c \cos \omega_c t \quad (14)$$

The frequency of the injected voltage carrier,  $\omega_c$ , should be high enough to ensure sufficient spectral separation

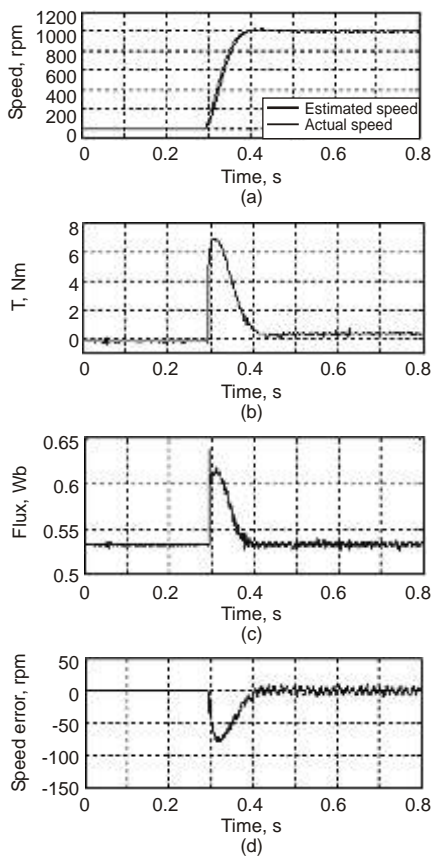


Figure 17 Start-up response of the sensorless drive (a) actual and estimated speeds, (b) estimated torque, (c) estimated flux, (d) speed estimation error (experiment)

between itself and the fundamental excitation to reduce the requirements of the band-pass filters. An alternating HF current response is detected in the  $q$ -direction of the estimated rotor reference frame with its amplitude modulated by the rotor position estimation error. The method of the demodulation process is shown in Figure 18. The high frequency component of measured current in the  $q$ -direction,  $i_{qc}$ , is obtained by band-pass filtering (BPF) of the  $q$ -axis component of measured current. The HF current signal is then demodulated and low-pass filtered (LPF) to extract an error signal given by equation (15).

$$= \text{LPF} \{ i_{qc} \sin ct \} \quad (15)$$

This error signal is ideally

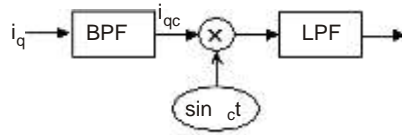


Figure 18 Demodulation scheme used to obtain error signal

$$e = K_e \sin 2\vec{\theta}_{rc} \approx 2K_e \vec{\theta}_{re} \quad (16)$$

where 
$$K_e = \frac{V_c L_q - L_d}{\omega_c 4L_d L_q}$$

$K$  is the signal injection gain and  $e = \hat{r}_e - r_e$  is the estimated error of the rotor position. A PI controller cascaded with an integrator can be used to drive the error to zero and to obtain the estimated rotor position signal. Hence, the closed-loop system constitutes a phase-locked loop (PLL) as depicted in Figure 19. Once the rotor position is obtained, flux estimation can be performed using the current model.

$$\begin{cases} \hat{\lambda}_d = L_d \hat{i}_d + \lambda_r \\ \hat{\lambda}_q = L_q \hat{i}_q \end{cases} \quad (17)$$

As the speed increases, the rotor position sensing accuracy falls and this leads to deterioration of performance. Hence, the injected test signal is disabled and other forms of observers have to be adopted at higher speeds. Change-over algorithms from signal injection to model-based estimators have been discussed in<sup>34-37</sup>.

Sensorless zero speed operation with nominal torque steps is depicted in Figure 20. The load was initially applied to the machine and was subsequently removed. It can be observed that the estimated speed tracks the actual speed very

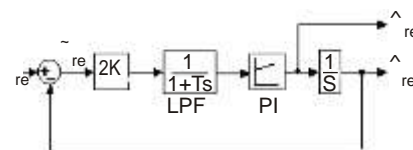


Figure 19 Phase-locked loop (PLL)

well and the speed estimation error is zero in steady-state. Hence, the sensorless drive is capable of persistent zero speed operation with full-load.

The low-speed dynamic response of the sensorless drive is shown in Figure 21. The machine is reversed from -10 rpm to 10 rpm with full-load. The estimated speed follows the actual speed very well during the reversal, confirming the effectiveness of the high frequency signal injection estimation method.

The signal injection method guarantees stable standstill and very low-speed operation at a lower overall efficiency. The high frequency injected signal is only used for rotor position sensing and not useful torque production.

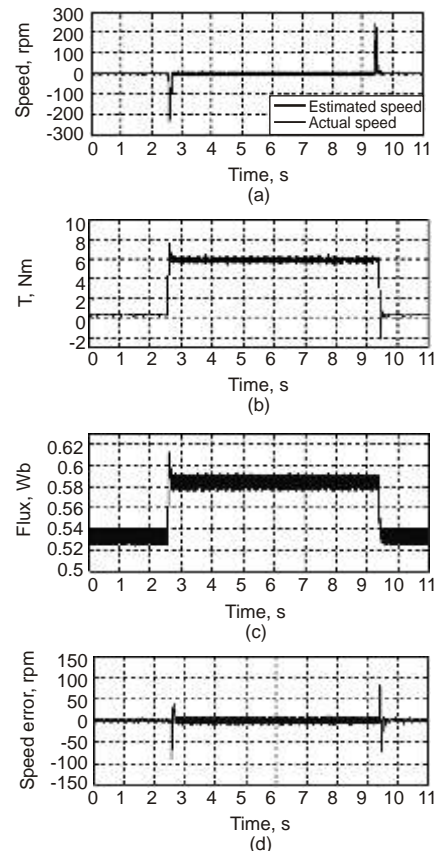


Figure 20 Full-load steps at standstill with signal injection (a) actual and estimated speeds, (b) estimated torque, (c) estimated flux, (d) speed estimation error (experiment)

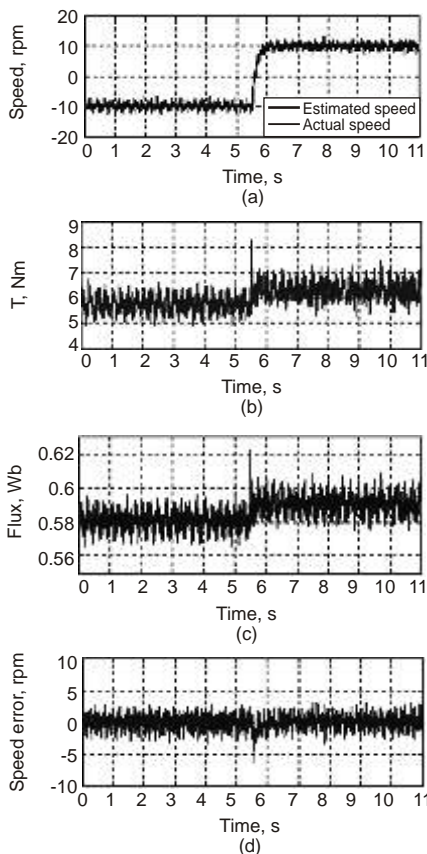


Figure 21 Full-load speed reversal from -10 rpm to + 10 rpm with signal injection (a) actual and estimated speeds, (b) estimated torque, (c) estimated flux, (d) speed estimation error (experiment)

Furthermore, the torque and flux ripples are now larger because of the high frequency currents in the machine. Torque and flux dynamics are also slightly compromised because of the additional filters in the system.

### INITIAL ROTOR POSITION DETECTION

All the observers discussed require the initial rotor position information for satisfactory start-up. It is important that the position is identified without generating any electromagnetic torque. The high frequency signal injection method can be used to detect the initial rotor position but  $r_e$  with an ambiguity of  $180^\circ$ . Two voltage vectors at angles  $r_e$  and  $r_e + 180^\circ$  are injected into the

machine. Due to saturation effects, the current amplitudes due to the respective voltage vectors will differ<sup>38</sup>. Hence, by comparing the amplitudes of the currents, the magnet polarity can be distinguished.

### CONCLUSION

High performance speed control of IPM motors without mechanical sensors has been explored in this paper. A number of solutions have been proposed to estimate the rotor position/speed using the measured stator currents and voltages. Open and closed-loop model-based estimation use the mathematical model of the machine. Without using any form of feedback, open-loop estimators possess the advantage of being simple but are susceptible to disturbances such as parameter variations, inverter nonlinearities and dc-measurement offset.

On the other hand, closed-loop observers use the current estimation errors as a correction term to further improve the estimation. As a result, they display stronger robustness to disturbances. When compared to speed adaptive observers, a lower operating speed limit of approximately 3 rpm can be achieved with speed non-adaptive observers because they are immune to speed estimation error which is inevitable in any type of observer. This low operating speed limit is sufficient for most velocity servo systems.

If persistent zero-speed operation is necessary, high frequency signal injection, exploiting anisotropies of the machine can be used. A high frequency test voltage is injected in the machine and the rotor position information is extracted from the current responses. Whilst guaranteeing permanent stability at

standstill and extremely low speeds, the effectiveness of this scheme deteriorates as the speed increases. Model-based estimators must be adopted at higher speeds. Furthermore, higher torque and flux ripples and a lower efficiency must be tolerated if this method is used in the sensorless velocity servo.

### REFERENCES

1. M Mengoni, L Zarri, A Tani, G Serra and D Casadei. 'Stator Flux Vector Control of Induction Motor Drive in the Field Weakening Region'. *IEEE Trans on Power Electron*, vol 23, March 2008.
2. L Tang, L Zhong, M F Rahman and Y Hu. 'A Novel Direct Torque Control for Interior Permanent Magnet Synchronous Machine Drive System with Low Ripple in Flux and Torque and Fixed Switching Frequency'. *IEEE Trans Power Electron*, vol 19, March 2004, p 346.
3. D Casadei, G Serra, A Stefani, A Tani and L Zarri. 'DTC Drives for Wide Speed Range Applications using a Robust Flux-weakening Algorithm'. *IEEE Trans. Ind Electron*, vol 54, October 2007, p 2451.
4. B Nahid-Mobarakeh, F Meibody-Tabar and F M Sargos. 'Back EMF Estimation-based Sensorless Control of PMSM: Robustness with Respect to Measurement Errors and Inverter Irregularities'. *IEEE Trans. Ind. Applicat.*, vol. 43, March-April 2007, p 485.
5. Z Xu and M F Rahman. 'Direct Torque and Flux Regulation of an IPM Synchronous Motor Drive using Variable Control Approach'. *IEEE Trans. Power. Electron.*, vol 22, November 2007, p 2487.
6. Z Xu and M F Rahman. 'An Adaptive Sliding Stator Flux Observer for a Direct Torque Controlled IPM Synchronous Motor Drive'. *IEEE Trans. Ind. Electron.*, vol 54, October 2007, p 2398.
7. M Rashed, P F A MacConnell, A F Stronach and P Acarnley. 'Sensorless Indirect-rotor-Field-orientation Speed Control of a Permanent Magnet Synchronous Motor with Stator Resistance Estimation'. *IEEE Trans. Ind. Electron.*, vol 54, June 2007, p 1664.
8. A Piippo, M Hinkkanen and J Luomi. 'Analysis of Adaptive Observer for Sensorless Control of Interior Permanent Magnet Synchronous Motors'. *IEEE Trans. Ind. Electron.*, vol 55, February 2008, p 570.
9. 'M Barut, S Bogosyan and M Gokasan'. Speed-sensorless Estimation for Induction

- Motors using Extended Kalman Filters'. *IEEE Trans. Ind. Electron.*, vol 54, February 2007, p 272.
10. M Barut, S. Bogosyan and M. Gokasan. 'Experimental Evaluation of Braided EKF for Sensorless Control of Induction Motors'. *IEEE Trans Ind. Electron.*, vol 55, February 2008, p 620.
11. S Bolognani, R Oboe and M Zigliotto. 'Sensorless Full Digital PMSM Drive with EKF Estimation of Speed and Position'. *IEEE Trans. Ind. Electron.*, vol 46, February 1999, p 184.
12. R Dhaouadi, N Mohan and L Norum. 'Design and Implementation of an Extended Kalman Filter for State Estimation of a Permanent Magnet Synchronous Motor'. *IEEE Trans. Power. Electron.*, vol 6, May 1991, p 491.
13. R Cardenas, R Pena, J Clare, G Asher and J Proboste. 'MRAS Observers for Sensorless Control of Doubly-fed Induction Generators'. *IEEE Trans. Power Electron.*, vol 23, May 2008, p 1075.
14. G D Andreescu, C I Pitic, F Blaabjerg and I Boldea. 'Combined Flux Observer with Signal Injection Enhancement for Wide Speed Range Sensorless Direct Torque Control of IPMSM Drives'. *IEEE Trans. Energy Conv.*, vol 23, June 2008, p 393.
15. 'A Piippo, M Hinkkanen and J Luomi. 'Signal Injection in Sensorless PMSM Drives Equipped with Inverter Output Filter'. *IEEE Trans. Ind. Applicat.*, vol 44, September-October 2008, p 1614.
16. C Caruana, G M Asher, K J Bradley and M S Woolfson. 'Flux Position Estimation in Cage Induction Machines using Synchronous Injection and Kalman Filtering'. *IEEE Trans. Ind. Applicat.*, vol 39, September-October 2003, p 1372.
17. A Khalil, S Underwood, I Hussain, H Klode, B Lequesne, S Gopalakrishnan and A M Omekanda. 'Four-quadrant Pulse Injection and Sliding Mode Observer-based Sensorless Operation of a Switched Reluctance Machine Over Entire Speed Range Including Zero Speed'. *IEEE Trans. Ind. Electron.*, vol 43, May-June 2007, p 714.
18. S Shinnaka. 'A New Speed-varying Ellipse with Voltage Injection Method for Sensorless Drive of Permanent Magnet Synchronous Motors with Pole Saliency New PLL Method using High-frequency-current Multiplied Component Signal'. *IEEE Trans. Ind. Applicat.*, vol 44, May-June 2008, p 777.
19. F Blaschke. 'The Principle of Field Orientation as Applied to the New TRANSVEKTOR Closed-loop Control System for Rotating-field Machines'. *Siemens Review*, vol 34, 1972, p 217.
20. G Foo, C S Goon and M F Rahman. 'Analysis and Design of the SVM Direct Torque and Flux Controlled IPM Synchronous Motor Drive'. *Australian Journal of Electrical and Electronics Engineering*. (To be published)
21. M F Rahman, M E Haque, L Tang and L Zhong. 'Problems Associated with the Direct Torque Control of an Interior Permanent Magnet Synchronous Motor Drive and their Remedies'. *IEEE Trans. Ind. Electron.*, vol 51, August 2004, p 799.
22. J W Choi and S K Sul. 'Inverter Output Voltage Synthesis using Novel Dead-time Compensation'. *IEEE Trans. Power Electron.*, vol 11, March 1996, p 221
23. J Holtz and J Quan. 'Sensorless Vector Control of Induction Motors at Very Low Speed using a Nonlinear Inverter Model and Parameter Identification'. *IEEE Trans. Ind. Applicat.*, vol 38, July-August 2002, p 1087.
24. J Holtz and J Quan. 'Drift- and Parameter-compensated Flux Estimator for Persistent Zero-stator-frequency Operation of Sensorless-controlled Induction Motors'. *IEEE Trans. Ind. Applicat.*, vol 39, July-August 2003, p 1052.
25. G Foo and M F Rahman. 'Wide Speed Direct Torque and Flux Controlled IPM Synchronous Motor Drive using a Combined Adaptive Sliding Mode Observer and HF Signal Injection'. *Journal of Power Electron*, vol 9, July 2009, p 582.
26. H Kubota, K Matsuse and T Nakano. 'DSP Based Speed Adaptive Flux Observer for Induction Motor Applications'. *IEEE Trans. Ind. Applicat.*, vol 29, March-April 1993, p 344.
27. J Maes and J Melkebeek. 'Speed Sensorless Direct Torque Control of Induction Motors using an Adaptive Flux Observer'. *IEEE Trans. Ind. Applicat.*, vol 35, May-June 2000, p 778.
28. J Holtz. 'Sensorless Control of Induction Machines With or Without Signal Injection?' *IEEE Trans. Ind. Electron.*, vol 53, February 2006, p 7.
29. C Lascu, I Boldea and F Blaabjerg. 'Comparative Study of Adaptive and Inherently Sensorless Observers for Variable-speed Induction Motor Drives'. *IEEE Trans. Ind. Electron.*, vol 53, February 2006, p 57.
30. I Boldea, M C Paicu and G D Andreescu. 'Active Flux Concept for Motion Sensorless Unified AC Drives'. *IEEE Trans. Power Electron*, vol 23, 12-2618, September 2008.
31. I Boldea, M C Paicu, G D Andreescu and F Blaabjerg. 'Active Flux DTFC-SVM Sensorless Control of IPMSM'. *IEEE Trans. Energy Conv.*, vol 24, June 2009, p 314.
32. G Foo and M F Rahman. 'Sensorless Vector Control of IPM Synchronous Motor Drive at Very Low Speed Without Signal Injection'. *IET Electric Power Applications*. (To be published)
33. G Foo and M F Rahman. 'Sensorless Direct Torque and Flux Controlled IPM Synchronous Motor Drive at Very Low Speed Without Signal Injection'. *IEEE Trans. on Ind. Electron*. (To be published)
34. C Silva, G M Asher, and M Summer. 'Hybrid Rotor Position Observer for Wide Speed-range Sensorless PM Motor Drives Including Zero Speed'. *IEEE Trans. Ind. Electron.*, vol 53, April 2006, p 373.
35. G Foo, S Sayeef and M F Rahman. 'Low Speed and Standstill Operation of a Sensorless Direct Torque and Flux Controlled IPM Synchronous Motor Drive'. *IEEE Trans. on Energy Conv*. (To be published)
36. G Foo and M F Rahman. 'Sensorless Sliding Mode MTPA Control of an IPM Synchronous Motor Drive using a Sliding Mode Observer and HF Signal Injection'. *IEEE Trans. on Ind. Electron*. (To be published)
37. S Sayeef, G Foo and M F Rahman. 'Rotor Position and Speed Estimation of a Variable Structure Direct Torque Controlled IPM Synchronous Motor Drive at Very Low Speeds Including Standstill'. *IEEE Trans. on Ind. Electron*. (To be published)
38. M E Haque, L Zhong and M F Rahman. 'A Sensorless Initial Rotor Position Estimation Scheme for a Direct Torque Controlled Interior Permanent Magnet Synchronous Motor Drive'. *IEEE Trans. Power Electron.*, vol 18, November 2003, p 1376.M

## Science and Engineering: Chandrayaan-1 Experience

### M Annadurai

*Project Director, Chandrayaan-1 and 2, ISRO Satellite Centre, Bangalore*

#### BACKGROUND

India recognized the potential of space science and technology for the socio-economic development of the society during the early days of space era and embarked upon development of an ambitious space programme. Over the last three decades, India has achieved significant progress in design, development and operation of space systems, as well as in using the systems for societal applications like telecommunication, television broadcasting, meteorology, disaster warning and natural resources survey and management. The Indian space programme has become largely self-reliant with capability to design, build and launch its own satellites using indigenously designed and developed launch vehicles, for providing space services to the country.

The state of maturity of spacecraft development at ISRO has been amply demonstrated with launch and maintenance of a series of remote sensing satellites in low earth polar orbit and communication satellites in geostationary orbit. Launch vehicle PSLV has been operationalized through successful demonstration of a series of flights to place spacecraft in low earth polar orbit. The GSLV had three successful flights to place communication satellites in geostationary orbit. The capability of PSLV to place a satellite in

geostationary orbit was demonstrated in 2002 when meteorological satellite, KALPANA-1 was launched. With these developments, ISRO is in a position to embark on newer missions. Lunar and interplanetary explorations provide such an opportunity. While managing the present there is a need to invent the future.

In the new millenium international scientific community has considered several exciting missions in space science and exploration. These have the prospect of expanding horizons of our knowledge effectively and will provide benefits to the human society at large. In the Indian context, one of the initiatives, which attracted debates and excited the imagination of a large number of people, was the possibility of launching a lunar mission through an Indian launcher. Groups of national scientists and technologists debated this in various fora under the aegis of Indian Academy of Sciences as well as Astronautical Society of India (ASI). Based on these interactions, and further study conducted by a National task team, the Chandrayaan-1 mission came into being, a mission where science and engineering teams needed to work seamlessly to realize the objective.

#### Mission Objectives

The overall objectives of the mission are summarized as

- Design, develop and launch a spacecraft in a lunar polar orbit using Indian launch vehicle.
- Develop expertise for planning and execution of mission and ground systems for sending spacecraft beyond the orbit around the earth for future planetary exploration missions.
- High resolution imaging and chemical and mineralogical mapping of lunar surface to understand the process of formation and chemical evolution of the moon.
- Systematic topographic mapping of the whole surface of the moon.
- To establish capability of planetary data analysis and also data archival and dissemination.
- To create expertise in development of detectors and sensor technology for planetary remote sensing for future planetary exploration programme.
- To enhance India's image in the international scene by being part of a select group having

capability to observe planets directly.

### Scientific Payloads

Chandrayaan-1 carried the following science instruments developed by ISRO to achieve the science objectives,

- Terrain mapping stereo camera (TMC) in the panchromatic band, having 5m spatial resolution (size of the smallest object that can be seen) and 20 km swath (width of the picture).
- A hyper-spectral camera (HySI) operating in 400-900nm band with a spectral resolution of 15nm and spatial resolution of 80m with a swath of 20km producing data in 64 spectral bands (colors)
- A laser ranging instrument (LLRI) with height resolution of about 10m.
- A low energy (1-10keV) X-ray spectrometer (LEX) for measuring the fluorescent X-rays emanating from the lunar surface having a foot print of approximately 20km. This instrument was realized as a joint effort by ISRO and Rutherford Appleton Laboratory, UK
- A high energy X-ray (30-270keV) mapping (HEX) employing CdZnTe solid state detector with CSI anti-coincidence system having a foot print of approximately 40km to identify degassing faults or zones on the moon by mapping Rn[222] and its

radioactive daughter Pb[210]. This will enable us to understand the transport of volatiles on the moon.

- A Moon Impact Probe (MIP) to be released to impact the Moon's surface during the Mission. MIP in turn carries three instruments, a mass spectrometer, a C-band altimeter and a video camera.

Apart from the five payloads (TMC, HySI, LLRI, LEX and HEX) and MIP discussed, five additional instruments under international collaboration were accommodated in Chandrayaan-1. They are,

- Miniature Imaging Radar Instrument (Mini-SAR) from Applied Physics Laboratory USA supported by NASA.
- Sub KeV Atom Reflecting Analyser (SARA) from IRF, Sweden, JAXA, Japan supported by ESA and VSSC, ISRO.
- Moon Mineralogy Mapper (M-3) from Jet Propulsion Laboratory and Brown University, USA, supported by NASA
- Infra Red Spectrometer-2 (SIR-2) from Max Plank Institute, Germany, supported by ESA
- Radiation Dose Monitor (RADOM), Bulgarian Academy of Science, Bulgaria.

Table 1 provides the summary of Chandrayaan-1 scientific instruments, their configuration and objectives.

### The Spacecraft and Launch Vehicle

Spacecraft for lunar mission had a judicious mix of the technologies of remote sensing satellites and communication satellites.

PSLV with enhanced performance was chosen for the Chandrayaan-1 mission to place the spacecraft in 260km × 22,860km orbit around earth. 440 N liquid fuel motor similar to that used in INSAT series of satellites was used for further orbit raising. The spacecraft was cuboids in shape of approximately 1.50m side, weighing about 625kg at lunar orbit. The spacecraft structure used in Kalpana satellite was adopted with minor modifications for extending the thrust cylinder and incorporating an upper payload deck to accommodate MIP and few other scientific instruments. The high gain antenna used for downloading the scientific data to the Indian Deep Space Network (IDSN) was a dual gimbaled system.

The spacecraft was three-axis stabilized. The orientation of the spacecraft orbit was precisely determined using star trackers and gyroscopes. Chandrayaan-1 had a canted (inclined) solar array to maximize the solar power for the orbit around the moon, which was inertially fixed. It generated about 750W of peak power and was supported by Li-Ion batteries for eclipse operations. The spacecraft carried a bipropellant propulsion system to carry it from EPO through lunar orbit, including orbit and attitude (direction) maintenance in lunar orbit. The propulsion system carried required propellant for a mission life of two years, with

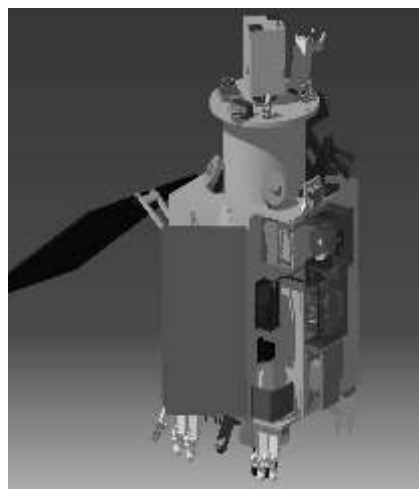
**Table 1 Chandrayaan-1 scientific instruments and their configurations**

Payload	Sensor configuration	Wavelength/energy range	Spatial Resolution	Objective
Hyperspectral imager (HySI)	Wedge filter & Silicon detector array	0.4--0.95 micro-meter with 15 nanometer resolution	80 m	Mineral mapping
Infra red spectrometer (SIR-2)	Grating spectrometer	0.90-2.6 micro-meter	100m	Mineral mapping
Moon Minera Mapper (M-3)	Grating spectrometer and HgCdTe detector	0.4--3.0 micro-meter with 10 nanometer resolution	30m	Mineral mapping and resource identification
Terrain mapping Camera (TMC)	Three stereo cameras using silicon detector array.	Panchromatic	5m	Topographic mapping
Laser Ranging (LLRI)	Pulsed Nd-Yag laser with optical system	1064nm	10m ( Height)	Topography
X-ray Fluorescence spectrometer (LEX)	Swept charged CCD	1-10 keV	20km	Chemical mapping (Mg-Fe)
Solar X-ray Monitor (XSM)	Si pin diode	2-10 keV	–	Solar X-ray Spectrum
High energy X-ray spectrometer (HEX)	CdZnTe detector	20-250 keV	40km	Th, Pb[210]
Synthetic Aperture Radar (mini SAR)	Radar, Scatterometer and altimeter	2.4 Ghz	100m	Soil Topography, altimetry, detection of polar ice
Sub KeV Neutral atom analyzer (SARA)	Mass spectrometer and solar wind monitor	10ev-2keV	100m	atmospheric neutrals (H-Fe) composition, Magnetic anomalies.
Radiation Dose Monitor (RADOM)	Si semiconductor	> 8 keV	–	Radiation dose

adequate margin. The TTC (Telemetry, Command and Tracking) system used microwave in the S-band and the scientific payload data transmission in X-band. Figure 1 provides the spacecraft configuration with payloads. Figure 2 gives the configuration of the polar satellite launch vehicle with its capability.

**The Mission Sequence**

Chandrayaan-1 was launched by PSLV- XL, a variant of flight proven PSLV, from Satish Dawan Space Centre, SDSC- SHAR. The spacecraft was injected into 260 km × 22,860 km orbit. After separation from the launcher solar panel was deployed. The spacecraft was raised to moon rendezvous orbit by five consecutive in-plane maneuvers at the perigee (closest location to the earth) to achieve the required 379,500km apogee. After the fifth perigee burn, the achieved lunar transfer trajectory (LTT) orbit was computed using tracking data received by the IDSN and a mid-course correction was imparted 24 h after the last perigee burn. The



**Figure 1 Chandrayaan-1 spacecraft configuration with payloads**

Lift off mass : 319 t  
 Payload lift off capability

- SSPO : 1750 kgs
- GTO : 1140 kgs
- EPO : 1320 kgs  
(260 km x 22860 km)

**Figure 2 PSLV-XL and its payload capability**

spacecraft coasted for about five days in this trajectory prior to the lunar encounter. During the coasting phase the spacecraft was staying mostly in the sun-pointed mode and at the same time ensuring good communication link to ground. The major maneuver of the mission, called lunar orbit insertion (LOI) leading to lunar capture, was carried out at the peri-selene (nearest point to the moon) part of the trajectory. The maneuver ensured successful lunar capture in a polar elliptical orbit of 500km × 7500km orbit around the moon. After successful capture and health checks, the altitude was lowered through a series of in-plane corrections to 100km near circular orbit. Figure 3 details Chandrayaan-1 Mission Sequence from launch to final orbit acquisition. The failures of others were studied in detail so that we did not repeat the same mistakes.

### Payload Commissioning

Moon impact probe was released on 14 Nov 2008. All the three instruments of MIP, namely, video camera, altimeter and the mass spectrometer have provided good data. Subsequently all other instruments of Chandrayaan-1 were

commissioned one by one as :

- RADOM : 23 Oct 2008 , one day after launch.
- TMC : 13 Nov 2008 ( in the moon orbit)
- MIP : 14 Nov 2008
- HySi : 16 Nov 2008
- LLRI : 16 Nov 2008
- M3 : 18 Nov 2008
- SIR-2 : 19 Nov 2008
- MiniSAR : 17 Nov 2008
- CIXS : 20 Nov 2008
- HEX : 5 Dec 2008
- SARA : 8 Dec 2008( low voltage commissioning)

All the instruments functioned satisfactorily. Figure 4 shows for the initial data of some of the instruments.

### Indian Deep Space Network (IDSN)

Establishment of IDSN was a vital element not only for Chandrayaan-1 but also to cater to future planetary missions. The existing ISTRAC/TTC and external S-band network supported slant range up to 100,000km during journey towards moon orbit. Beyond this range

during the mission profile and at lunar distance of approximately 400,000 km, IDSN was used both for TTC and payload data reception. The spacecraft position in orbit was determined using radio frequency ranging technique and computation of orbital parameters based on the measurement of range and rate of change of range. Two ground terminals one with 18m antenna and another with 32 m antenna had been established at Byalalu village near Bangalore as a part of IDSN. Though 18m terminal was sufficient for Chandrayaan-1, 32m antenna provided further margins and would cater to the futuristic needs also. ECIL, Hyderabad had the prime responsibility of realizing 32m antenna with the technical contributions from ISTRAC, ISAC, BARC and others. Figure 5 depicts IDSN antenna.

Compared to the International Deep Space Network stations of, Goldstone California, USA, the Bangalore IDSN has 180 longitudinal shift with respect to longitude and is centrally located with respect to the other two DSNs, namely, Villa Franca, Spain, and Perth, Australia. Establishing IDSN at Bangalore had the potential of commercial benefit since it could be useful to international space agencies for their planetary missions.

### Indian Space Science Data Centre (ISSDC)

The IDSN in Bangalore receives the payload data. The data in its raw form along with auxiliary data is sent to Indian Space Science Data Centre (ISSDC) that has been set up in Bangalore. ISSDC would process

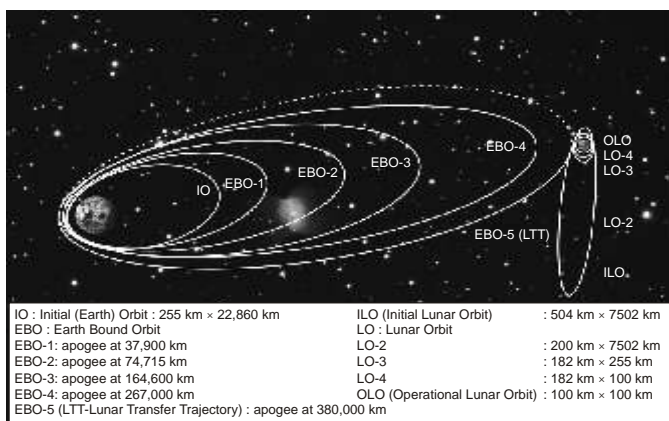


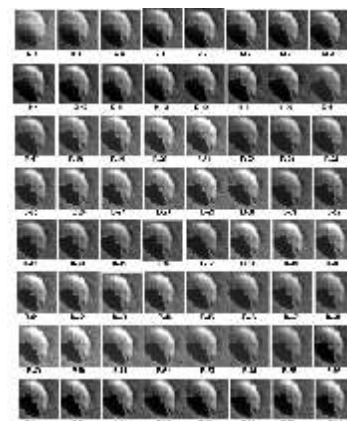
Figure 3 Chandrayaan-1 mission sequence



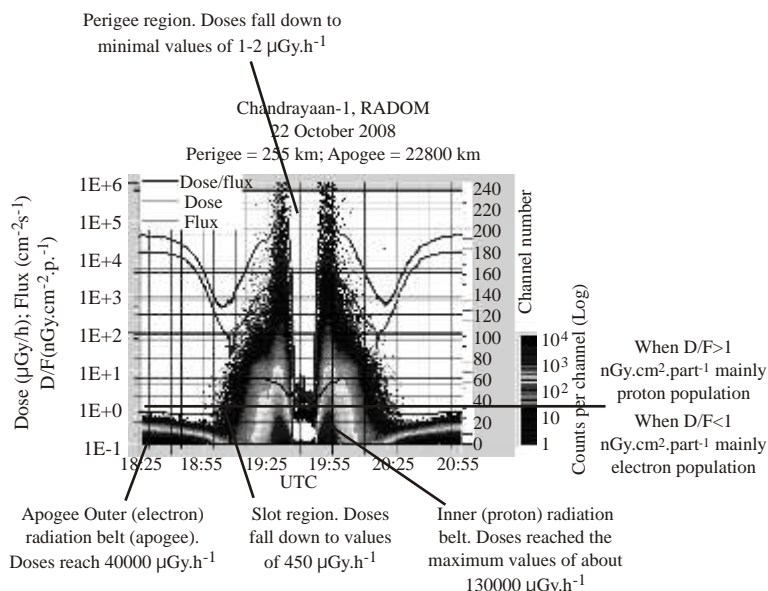
**Figure 4a.** The close up pictures of the moon's surface taken by Moon Impact Probe (MIP) on November 14, 2008 as it approached it after separating from Chandrayaan-1 spacecraft, these pictures are reproduced as received.



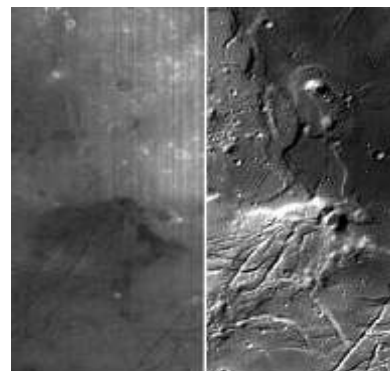
**Figure 4b.** the picture of moon's surface taken from lunar orbit by Chandrayaan-1 spacecraft's Terrain Mapping Camera (TMC) on November 15, 2008 . The bright terrain on the lower left is the rim of 117 km wide Moretus crater.



**Figure 4e.** Lunar craterlet (BARROW H) imaged by Chandrayaan-1 HySI camera (64 Bands) on 16 Nov. 2008.

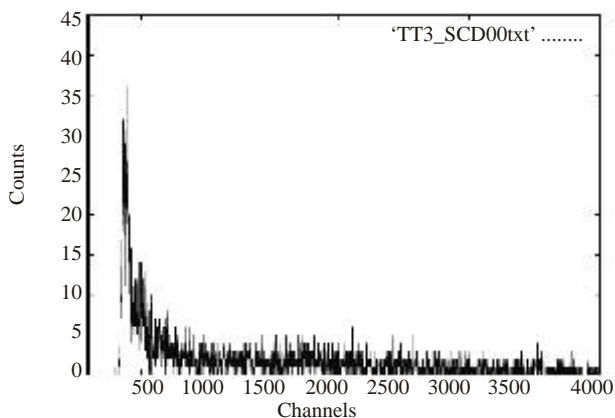


**Figure 4c.** RADOM data

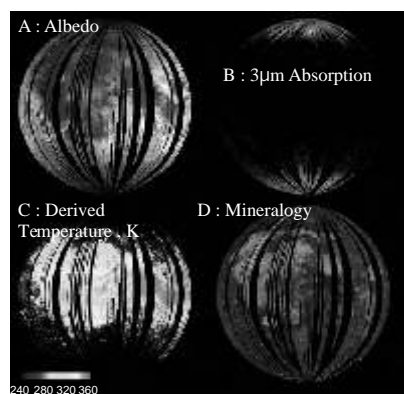


The image strip on the left is a color composite of data from 28 separate wavelengths of light reflected from the moon. The image strip on the right is from a single wavelength of light that contains thermal emission, providing a new level of detail on the form and structure of the region's surface

**Figure 4f.** M3 composite image of the Orientale region



**Figure 4d.** CIXS - first lunar spectrum



**Figure 4g.** M3 Lunar coverage outputs A: Moon Albedo map/the sun light reflected from the surface of the moon. B: M3 image where infrared light is absorbed by water and hydroxyl molecules, largely concentrated towards the lunar poles. C: derived moon surface temperature. D: Initial results of the mineral map.



Figure 5. Bangalore IDSN

the raw data and convert it into user-friendly form. The data centre also archives all the payload data and is the focal point for foreign payload teams as well.

### Present Status and the Road Ahead

Chandrayaan-1 Spacecraft along with all 11 scientific instruments was fully functional in its targeted 100km lunar polar orbit. All the newly built ground systems were fully operational. The scientific outputs as derived from Chandrayaan-1 instruments data will be released after due reviews by Chandrayaan-1 science team. The experience gained in realizing Chandrayaan-1 mission will be fully utilized for the upcoming Chandrayaan-2 mission along with the mission specific updates.

### Summary

The technical objectives of the mission namely, a) to design, develop and launch a spacecraft in a lunar polar orbit using Indian launch vehicle and b) to develop expertise for planning and execution of mission and ground systems for sending spacecraft beyond the orbit around the earth for future planetary exploration missions c) providing high quality data from all 11 science instruments amounting more than 6TB of data volume have been fully accomplished and initial findings like discovery of water, local magnetic field, radiation environment and radar images of the lunar poles are quite encouraging.

The scientific objectives of higher resolution topographic mapping of the Moon and imaging in X-rays identified for the present mission are unique experiments in many ways and would provide insight into the chemical composition of the moon and frequency of small impactors. A comprehensive image and topography of the moon will be generated using data from Chandrayaan-1 instruments in the coming months. Such a topography database would be valuable for onward research, by both Indian and the international science teams. It will also enable us to understand the lunar surface features for a more

systematic planning of future missions.

The Indian mission to the moon should be seen beyond the scientific results it has produced. Studies have shown that the moon could serve as a source of economic benefit to mankind and could be of strategic importance. The moon can be both, a beacon and a focus for the next generation of space exploration which will accrue new and important benefits, to the people of all nations and the earth.

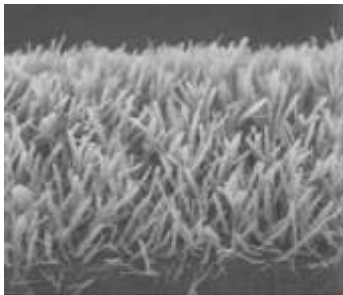
Just a few decades back, man never imagined that he would set foot on the moon. Decades from now, human colonies on the moon could become a reality. India should also be in the forefront of this challenging and exciting endeavor. Chandrayaan-1 mission is a well thought out mission in this direction and has lived up to the expectations paving the way for future lunar missions. The lessons learnt while managing Chandrayaan-1 could very well translate into a good message to the youth to be future leaders of different mindset. Chandrayaan-1 has demonstrated a good team spirit between engineers and scientists, setting an example for other ongoing projects in planetary science and as well for emerging interdisciplinary fields.

*Text of the 52<sup>nd</sup> Sir M Visvesvaraya Memorial Lecture, delivered at the 24<sup>th</sup> Indian Engineering Congress, Mangalore, December 10-13, 2009*



## Window Cleaner — A Thing of the Past

Operating in the range of 100 nanometers (roughly one-billionth of a meter) and even smaller, graduate student Lihi Adler-Abramovich and a team working under Prof. Ehud Gazit in TAU's Department of Molecular Microbiology and Biotechnology have found a novel way to control the atoms and molecules of peptides so that they "grow" to resemble small forests of grass. These "peptide forests" repel dust and water — a perfect self-cleaning coating for windows or solar panels which, when dirty, become far less efficient. Using a variety of peptides, which are simple and inexpensive to produce, the



TAU's nanosized "forest of peptides" can be used as the basis for self-cleaning windows and more efficient batteries. (Credit: Image courtesy of American Friends of Tel Aviv University)

researchers create their "self-assembled nano-tubules" in a vacuum under high temperatures. These nano-tubules can withstand extreme heat and are resistant to water.

Coated with the new material, the sealed outer windows of skyscrapers may never need to be washed again — the TAU lab's material can repel rainwater, as well as the dust and dirt it carries. The efficiency of solar energy panels could be improved as well, as a rain shower would pull away any dust that might have accumulated on the panels. It

means saving money on maintenance and cleaning, which is especially a problem in dusty deserts, where most solar farms are installed today.

## Animal Robots that can climb walls



Amir Shapiro, Head of the Robotics Lab in the Mechanical Engineering Department at Ben-Gurion University of the Negev, in Beersheba, Israel has developed robots that can climb walls by releasing melted glue, which holds it in place until it can move forward and release more glue. These can be used for intelligence gathering. For rough walls, a robot is designed with four legs carrying fishhooks, allowing it to climb like a cat. He has also equipped a robot with compliant magnetic wheels so that it can clamber on the submerged hulls of cargo ships, perhaps one day replacing the divers who now check for contraband and bombs." A robot can do it safer, better, easier and much less expensively" says Shapiro.

## Integrated Motor Controller

The motion control market is achieving evolutionary changes with motors and motor controllers gravitating toward higher performance, functionality and intelligence driven by software advancements. Electric components are now integrated with motors to incorporate controllers and actuators saving space and giving designers more flexibility in designing motor control systems.

According to a report by the Motion Control association (MCA), motors—brush and brushless, servomotors with gearings mounted, direct drive, linear motors and steppers. Accounted for the largest percentage of motion control sales at 36.5%

As motors scale up the performance curve, smaller motors are offering the performance of the larger counterpart. One motor trend is the use of piezo motors for linear actuation. These motors, which replace traditional linear motors used with ball screws or lead screws provide precise positioning.

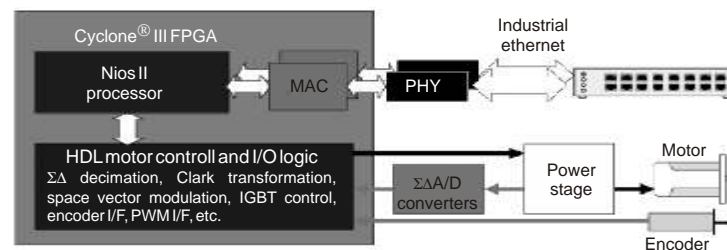


The MDrivePlus™ variable speed control from Intelligent Motion Systems exemplifies the trend toward integrated motor controllers.

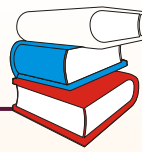
## FPGA and Industrial Ethernet in Motion Control Systems

Industrial Ethernet (IE) is a rapidly growing technology, both in terms of rate of adoption and evolution. A board that carries a low cost FPGA device and Ethernet PHY transactions can, with appropriate hardware and software IP, support any IE standard. As the FPGA is programmable, it can be easily re-configured to support any new protocol; this can be done at any time even if the device is in a machine already on the

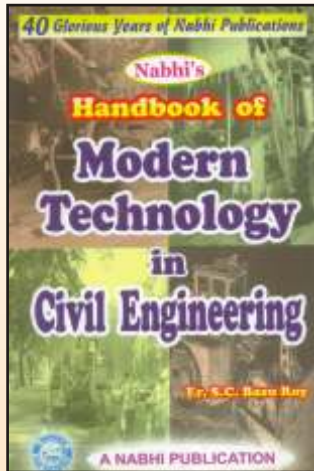
factory floor. FPGA devices offers the ability to absorb all the digital logic and like PWM in a drive system. They can be cheaper and of lower power than one based on a multi-standard ASIC device. The flexibility and power delivered by the combination of IE and FPGA devices also brings about the opportunity to open up the way drive systems are put together along with more intelligence.



Example of an FPGA-based motor controllers system



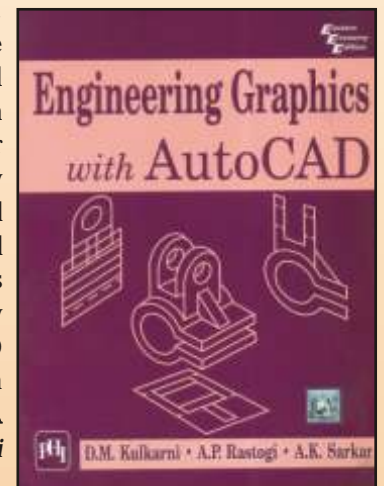
## Book Shelf



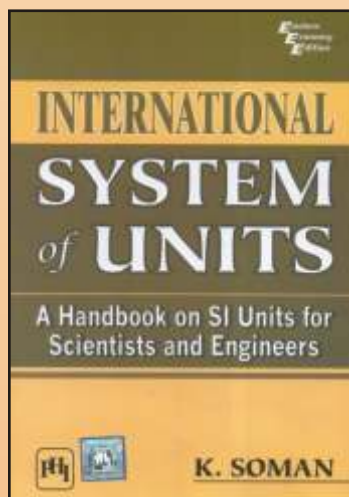
**Handbook of Modern Technology in Civil Engineering** : This book has sorted out various problems associated with civil engineering as well as engineering issues of municipal services. The book covers areas, essentially required for successful execution of construction and maintenance projects. With respect to the management of safety aspects, attention of the practicing engineers has been drawn towards the practice of TQMC and TQM in the design and maintenance of construction. The different chapters of the book have been organized in order to meet the requirements of total quality management. Different safety aspects, upgradation of technology, introduction of new technologies have been briefly discussed along with other important issues, which include private house construction and water leakage in urban supply system and its remedy. **S C Basu Roy**, A Nabhi Publications, Po Box No. 37, New Delhi 110 001, pp 404, Rs. 290/-.

**Engineering Graphics with AutoCAD** : Designed as a text for the undergraduate students of all branches of engineering, this compendium gives an opportunity to learn and apply the popular drafting software AutoCAD in designing projects.

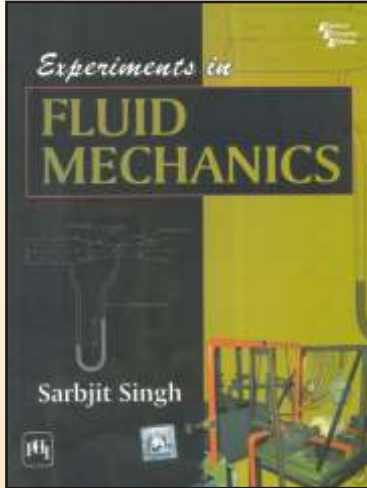
The textbook is organized in three comprehensive parts. Part I (AutoCAD) deals with the basic commands of AutoCAD which is widely used as drafting software by engineers and architects. Part II (Projection Techniques) contains various projection techniques used in engineering for technical drawings. These techniques have been explained with a number of line diagrams to make them simple to the students. Part III (descriptive geometry) mainly deals with 3-D objects that require imagination. Unlike conventional textbooks, the model solutions and exercise problems are independent of dimensions. Therefore, this book will also be useful for the students who use conventional drafting techniques. Key features include, fundamentals of imagination skill in generic and basic forms to crystallize key concepts in engineering graphics, chapters on aspects of technical drawing and AutoCAD as a tool, problems in the third angle as well as first angle methods of projection in line with the revised code of Indian Standard Code of practice for general drawing. **D M Kulkarni, A P Rastogi and A K Sarkar**, PHI Learning Pvt. Ltd., M-97, Connaught Circus, New Delhi 110 001, pp 326, Rs. 325/-.



**International System of Units** : This book contains comprehensive reference material on the use of the International System of Units (SI system), which is now the world's most widely used system of measurement, developed in 1960 from the metric system. As some countries, notably the United States and the United Kingdom, still continue to use customary units in addition to SI, this book also provides information on CGS, FPS and MKS systems of units. The book is organized into 12 chapters. The first nine chapters acquaint the readers with the definitions of the base units in the SI system, application of prefixes, realization of derived and supplementary units, conversion factors, general physical data, and several examples to illustrate the use of conversion factors between the units used in different systems. The book also contains engineering related data, in SI units, on properties of some metals, alloys and polymers for use by design engineers. Data on threaded fasteners is also presented in SI units. Besides, there is miscellaneous information, such as properties of gases, paper sizes, solar system, and earthquake severity measurement scale, presented in the context of the use of the SI system. The book will be useful as a handy guide to the students of science and engineering, technicians, scientists and engineers, as well as authors and editors of technical books. **K Soman**, PHILearning Pvt. Ltd., M-97, Connaught Circus, New Delhi 110 001, pp 106, Rs. 125/-.



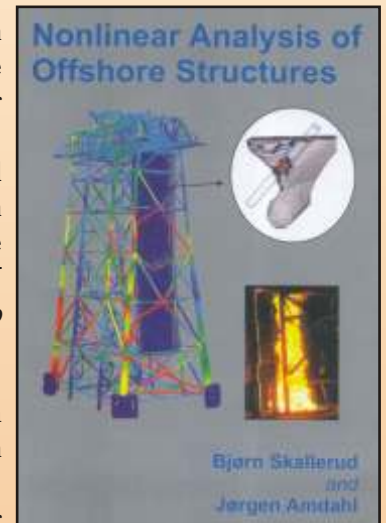
## Book Shelf



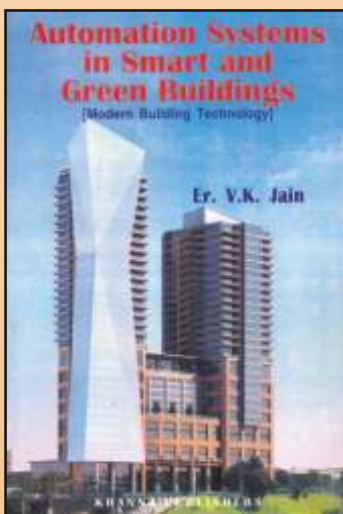
**Fluid Mechanics** : The aim of this book is to teach the students, how to conduct experiments in fluid mechanics. The book is designed for use by undergraduate students of several branches of engineering. Thirty experiments have been selected on basic and advanced fluid mechanics. The first fifteen experiments are designed to be performed by the students of several branches of engineering who study fluid mechanics as a common course (civil, mechanical, electrical, instrumentation and control, and chemical engineering). The remaining fifteen experiments are meant to be performed by the students of civil engineering and mechanical engineering who study advanced course on fluid mechanics. The book is divided into two parts. Part I allows the students to review the fundamental theory before stepping into laboratory environment. Part II provides the step-wise details of experiments which include objective, brief theory of the experiment, experimental set-up, procedure, observations and calculations, graphs to be plotted, and a concluding discussion of the experiment. Appendix A gives several questions based on each experiment to test the student's understanding of the learned material. Appendix B gives data on physical properties of water, air, and some commonly used fluids in the

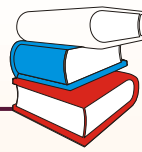
laboratory, and also lists other related standard values to be used in the various experiments. **S Singh**, PHI Learning Pvt. Ltd., M-97, Connaught Circus, New Delhi 110 001, pp 225, Rs. 225/-.

**Nonlinear Analysis of Offshore Structures** : The book provides first hand information in the advanced methods for analysis of offshore structures subjected to extreme loads like abnormal wear, ship collision and fire. The book addresses main aspects of nonlinear analysis of offshore structures that include basic nonlinear continuum mechanics, modelling alternatives for simulation of tubular members and system behaviour and reassessment of offshore structures. The book further includes recent developments in assessing the capacity of offshore structures. The objective of the book is to balance between theory, practical modelling and engineering applications. **B Skallerud and J Amdahl**, Standard Publishers Distributors, 1705-B, Nai Sarak, New Delhi 110 006, pp 323, Rs. 395/-.

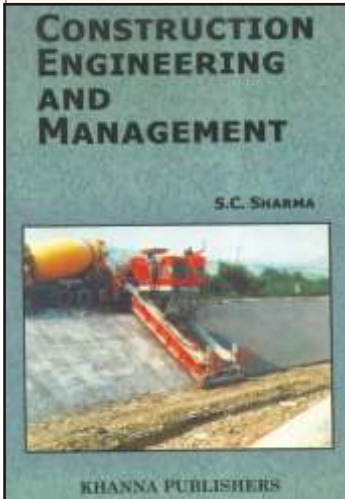


**Automation Systems in Smart and Green Buildings** : An intelligent building provides a productive and cost effective environment through optimization of its four basic elements namely, structures, systems, services and management and their corresponding interrelationships. Buildings, which adopt the best practices of environmental technology for optimizing the use of natural resources to provide a clean and cost effective work ambience, known as green building. Any building incorporating the concept of intelligent and green buildings are known as smart buildings. This book is meant for architects, engineers, practitioners and all stakeholders who are involved in promoting, designing, constructing or operating buildings. This will include building owners and clients as well as facilities managers and those who design and construct buildings. It will also serve as a reference text for students in architecture, building environmental engineering and other courses concerned with the built environment smart sustainable and intelligent buildings. **V K Jain**, Khanna Publishers, 4575/15, Onkar House, Opp. Happy School, Darya Ganj, New Delhi 110 002, pp 1254, Rs. 300/-.



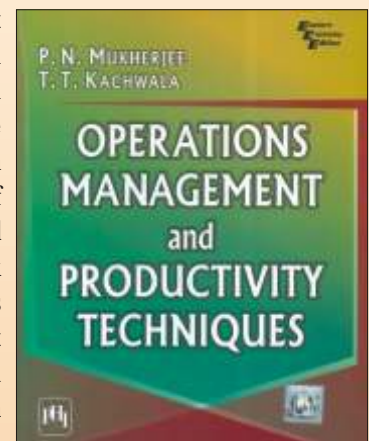


## Book Shelf

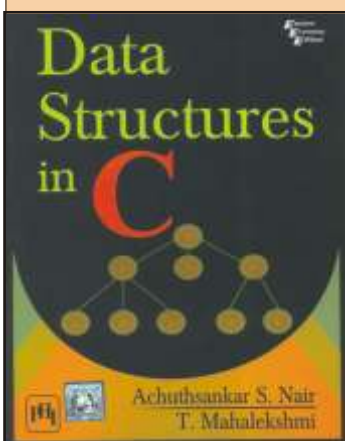


**Construction Engineering and Management :** The book on construction engineering and management meets the long felt need of comprehensive book for indepth study of various essential aspects of a construction techniques for infrastructure projects and construction management which highlights the concepts and principles of management for managing resources, finances, materials and equipments. The implementation aspects like infrastructure development, safety and post construction management techniques are also discussed in the book. The book also deals with the latest development in the field of various construction activities/methods. **S C Sharma**, *Khanna Publishers, 2-B, Nath Market, Nai Sarak, New Delhi 110 006, pp 790, Rs. 195/-*.

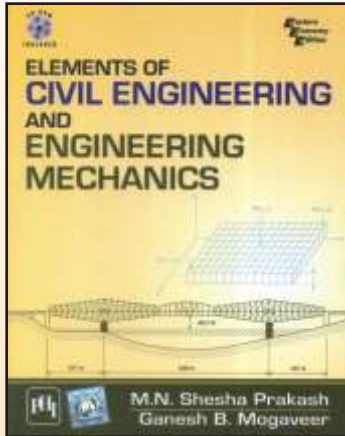
and efficient way for carrying out a business process with the objective of optimum customer satisfaction and favourable return on investment. Further concepts of productivity implies effectiveness and efficiency in individual and organizational performance, reflected in the creation of surplus through productive operations. The book provides the readers with on easy to understand treatment of all aspects of operations management and explains the expanded coverage of the role of operations management in the organization. While focussing on the basic principles and core operations in a straight forward and well structured manner, the book provides students with an understanding of different functions of management in the areas like TQM, SPC, TPM, Supply Chain Management and so on. It is . hoped that this book will fulfill the requirement of the students in the area of operations management. The book also deals with he practical approaches to increase the productivity of an organization in a simple and definitive manner. **P N Mukherjee and T T Kachwala**, *PHI Learning Pvt. Ltd., M-97. Connaught Circus, New Delhi 110 001, pp 416, Rs. 325/-*.



**Data Structures in C :** This compact and student friendly book deals with data structures, particularly user defined data structures, such as linked lists, stacks, queues, trees, graphs and files, using C as the programming language. The text begins with an introduction to the most common concepts of C and then it goes on to give a detailed discussion on the processing of one dimensional and two dimensional arrays, their internal organization, and handling arrays using pointers. Besides, it dwells on the dynamic linked list and its variations such as doubly linked lists and circular linked lists, with the help of memory diagrams. The text delineates the static and dynamic implementations of stacks and queues, the application, implementation, and construction of binary trees, and representation of graphs and graph traversal. The book concludes with a discussion on the various types of searching and sorting techniques, with the help of visual examples. Key features include visualization model for abstract concepts, the shortest possible program and conceptual exercises before programming examples. The book is intended for the undergraduate students of engineering, computer science, information technology, and undergraduate and postgraduate students of computer application, computer science and information technology. **A S Nair and T Mahalekshmi**, *PHI Learning Pvt. Ltd., M-97. Connaught Circus, New Delhi 110 001, pp 281, Rs. 250/-*.



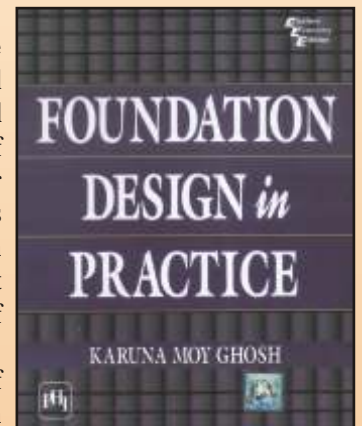
## Book Shelf



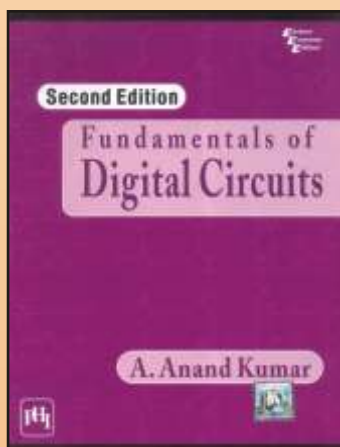
**Elements of Civil Engineering and Engineering Mechanics :** Student friendly in approach, this book focuses on introductory coverage of basic of civil engineering and engineering mechanics to provide students with a balanced and cohesive study of these two areas as needed by them in the beginning of their engineering education. It is a basic undergraduate textbook for first year students of all branches of engineering. The book imparts basic knowledge in various facets of civil engineering and the related engineering structures and infrastructure such as buildings, roads, highways, dams and bridges, inter alia, emphasizing the role and responsibilities of a civil engineer in the modern society. It also briefly explains the broad scope of allied fields of civil engineering such as surveying, transportation, water resources, environmental engineering, geotechnical engineering, foundation engineering, and construction technology. The engineering mechanics portion of the book is comprehensively covered in eight chapters, divided into topics on forces, centroid, moment of inertia and friction. Providing a wealth of practice examples, the book emphasizes the importance of building strong analysis skills. Practice problems at the end of each chapter

provide the opportunities to absorb concepts and hone their problem solving skills. This book has a companion CD containing software, developed using MS Excel to work out the problems on forces, centroid, friction and moment of inertia. It would help faculty to develop new kind of problems with reliable solutions for use in tests and examinations. The use of this software will enable the students to understand the concepts in a relatively better way. They will also be able to compare answers with those obtained using manual procedures. **M N S Prakash and G B Mogaveer**, PHI Learning Pvt. Ltd., M-97. Connaught Circus, New Delhi 110 001, pp 280, Rs. 225/-.

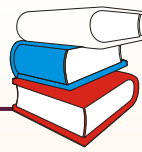
**Foundation Design in Practice :** The behaviour of foundation is closely interlinked with the behaviour of soil supporting it. This book develops a clear understanding of the soil parameters, bearing capacity, settlement and deformation, and describes the practical methods of designing structural foundations. The book analyses the various types of foundations, namely isolated footing, strip foundation and raft foundation and their structural design. It discusses piled foundation, the types and behaviour of piles in various soils and their bearing capacity. The book also includes the analysis, design and construction of diaphragm wall foundation used in highway and railway tunnels, multi-storey basement and underground metro stations. In addition, the book includes the analysis and design of sheet piling foundation, retaining wall and bridge pier foundation. Key features includes, demonstration of both BS codes and Eurocodes to analyze soil and structural design of foundations and comparison of the results, introduction of sufficient number of examples on foundation, provide structural design calculations with step by step procedure and inclusion



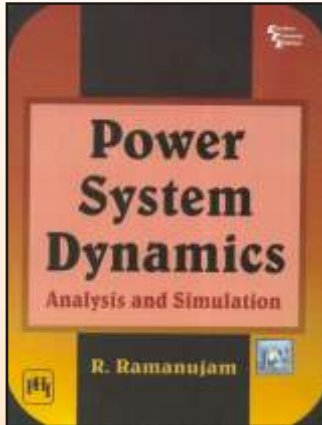
of sufficient number of relevant sketches, figures and tables to reinforce the concepts. **K M Ghosh**, PHI Learning Pvt. Ltd., M-97. Connaught Circus, New Delhi 110 001, pp 332, Rs. 295/.



**Fundamentals of Digital Circuits :** Written in a student friendly style, the book provides an excellent introduction to digital concepts and basic design techniques of digital circuits in a simple and lucid manner with emphasis on practical treatment of real world applications. It discusses the concept of Boolean Algebra and its application in digital circuit and elaborates on both combinational and sequential circuits. This comprehensive textbook on digital circuits is developed to provide a solid grounding in the foundations of basic design techniques. A large number of typical examples have been worked out, so that the students can understand the related concepts clearly. The book blends basic digital electronic theory with the latest in digital technology. **A A Kumar**, PHI Learning Pvt. Ltd., M-97. Connaught Circus, New Delhi 110 001, pp 918, Rs. 375/-.



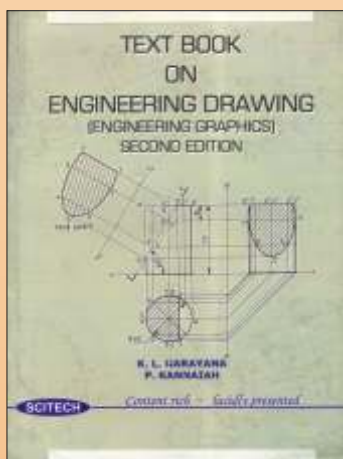
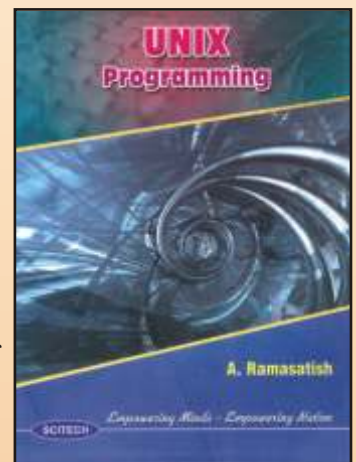
## Book Shelf



**Power System Dynamics Analysis and Simulation** : This comprehensive text offers a detailed treatment of modelling of components and sub-systems for studying the transient and dynamic stability of large-scale power systems. Being with an overview of basic concepts of stability of simple systems, the book is devoted to in-depth coverage of modeling of synchronous machine and its excitation systems and speed governing controllers. Apart from covering the modeling aspects, methods of interfacing component models for the analysis of small-signal stability of power systems are presented in an easy to understand manner. The book also offers a study of simulation of transient stability of power system as well as electromagnetic transients involving synchronous machines. Practical data pertaining to power systems, numerical examples and derivations are interspersed throughout the text to give students practice in applying key concepts. This text serves as a well-knit introduction to

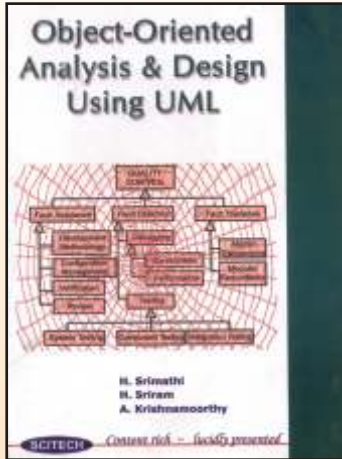
power system dynamics. **R Ramanujam**, *PHI Learning Pvt. Ltd., M-97, Connaught Circus, New Delhi 110 001, pp 514, Rs. 425/-.*

**UNIX Programming** : UNIX is the basis for some of the most commonly applied operating systems today, which include Sun's Solaris UNIX and IBM/s AIX. Today many of the versions of UNIX are available free to users and corporations, allowing for larger use. UNIX is now observed as a user friendly, very secure, and robust operating system rather than cold, command line only operating system. In order for the students and faculty of this course to understand the subject thoroughly, this book has been developed with extreme care. The salient features of this book includes, applications of simple language, diagrams for quick understanding, in-depth coverage of all important topics and review questions for further assessment. Different chapters of the book presents UNIX introduction, features of UNIX, various utilities of UNIX operating system, in-depth discussion of grep family and sed utility, korn shell, C shell, file handling using functions of ANSI C, process and signal handling, record locking and various IPC mechanisms. **A Ramasatish**, *SCITECH Publications (India) Pvt. Ltd., 7/3C, Madley Road, T Nagar, Chennai 600 017, Rs. 285/-.*



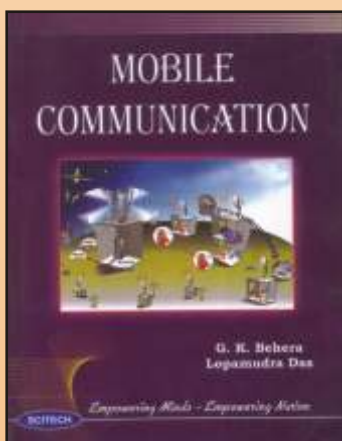
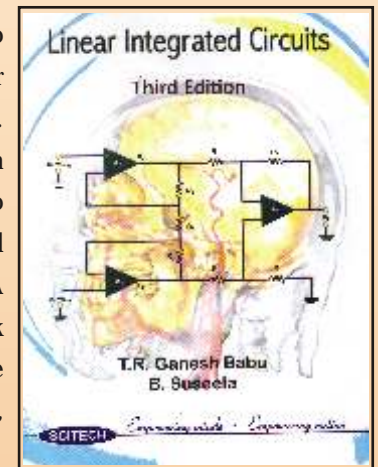
**Text Book on Engineering Drawing (Engineering Graphics)** : The subject content is this book is presented by adopting a new style in the form of step-by-step construction procedure so that it can be easily understood. The book is the first of its kind to follow the latest BIS standards in the presentation of drawings. This book contains 1000 figures, with numerous examples, satisfying the requirements of students to understand the subject in depth. Short questions and answers are also provided at the end of each chapter which will help the students in self study and the teacher in assessing the students ability. **K L Narayana and P Kannaiah**, *SCITECH Publications (India) Pvt. Ltd., 7/3C, Madley Road, T Nagar, Chennai 600 017, Rs. 225/-.*

# Book Shelf

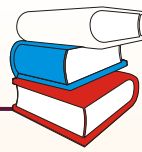


**Object-Oriented Analysis and Design Using UML :** Object orientation provides a set of powerful concepts to analyze some of the more complicated problems of software quality. It contribute, reliability, extensibility, reusability etc., improving the efficiency of the system. It adopts data centric methodology and has distinct advantages over the conventional functional methods, which adopt algorithm centric methodology. The object oriented software development processes are dealt in this book right from the basic level. The book follows the development of a small software system from the initial identification of the problem through to the final software product. The advantages of using OOAD to build high quality, reusable software methods are well demonstrated. The need for unified approaches, focus on IML diagrams and how it is used in analyzing the problems domain using use case diagrams and methodologies are also discussed. Introduction to CBD, patterns, ODBMS, distributed object computing, RUP, extreme programming are also included in this textbook. It also covers testing fundamentals and object oriented testing concepts. All the case studies include relevant UML diagrams for better understanding of the readers. **H Srimathi, H Sriram and A Krishnamoorthy, SCITECH Publications (India) Pvt. Ltd., 7/3C, Madley Road, T Nagar, Chennai 600 017, Rs. 190/-.**

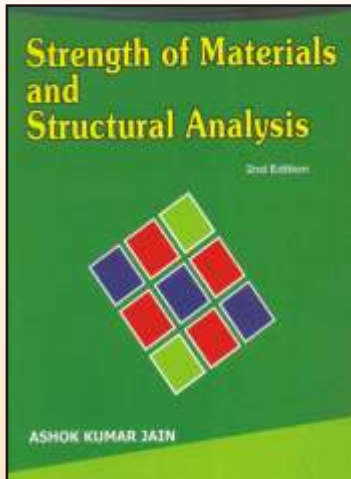
**Linear Integrated Circuits :** The book provides a comprehensive step-by-step guide to different aspects of linear integrated circuits, which include circuit configurations for linear ICs, IC operational multipliers, analog multipliers, digital and analog converters and so on. The contents of the book are presented in lucid style so that even an average student can grasp the subject. More number of simple and complex problems are worked out to strengthen the understanding of the subject. Most of the topics are presented in a lucid manner so that the students of the various branches can easily understand the subject. A large number of worked out examples and assignment problems are given. The book covers the entire syllabi of many universities in India. Fully solved question papers are included. **T R G Babu and B Suseela, SCITECH Publications (India) Pvt. Ltd., 7/3C, Madley Road, T Nagar, Chennai 600 017, Rs. 190/-.**



**Mobile Communication :** The area of mobile communication has emerged today as one of the fast growing technologies worldwide. This book offers detailed treatment of the entire technology in both theory and practice to fulfill the needs of communication and electrical engineering students. It will also be of interest to teachers, professional telecom engineers, researchers and pupils who opt to work in the field of mobile communication and those who want to improve their knowledge of mobile communication techniques. The principle objective of this book is to provide an introduction to the basic concepts and methodologies for mobile communication and to develop a foundation, that can be used as the basis for further study and research in the field of communication engineering. **G K Behera and L Das, SCITECH Publications (India) Pvt. Ltd., 7/3C, Madley Road, T Nagar, Chennai 600 017, Rs. 390/-.**

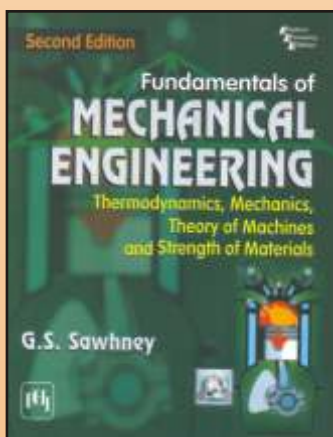
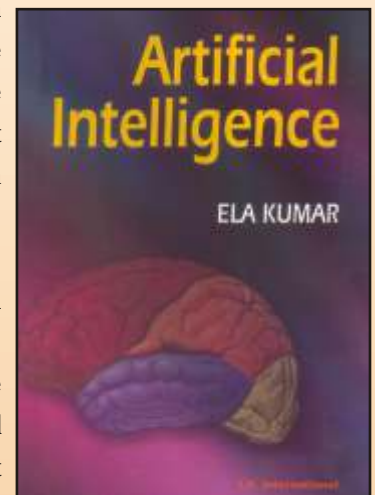


## Book Shelf



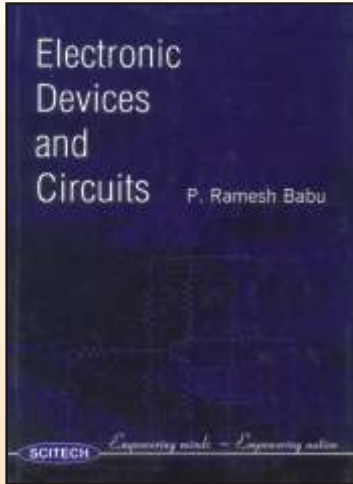
**Strength of Materials and Structural Analysis :** The purpose of the book is to provide an introductory text in the field of strength of materials and structural analysis. The book attempts to fill the gap between mechanical properties of materials and concept of safety with respect to stresses and strains. The primary objective of this book includes understanding the concept of stresses and strains, their various components at a given point in solid, develop the relations between the loads applied to a elastic body and the resulting stresses, develop the basic relations between stresses and strains and to be able to determine various force components due to the applied load in statically determinate structures have different structural elements and boundary conditions. **A K Jain, Nem Chand and Bros, Civil Lines, Roorkee 247 667, pp 665, Rs. 295/-.**

**Artificial Intelligence :** Artificial Intelligence (AI) is an emerging discipline of computer science. It deals with the concepts and methodologies required by computer to perform an intelligent activity. The spectrum of computer science is very wide and it enables the computer to handle almost every activity, which human beings can. It deals with defining the basic problem from viewpoint of solving it through computer, finding out the total possibilities of solution, representing the problem from computational orientation, selecting data structures, finding the solution through searching the goal in search space dealing, with the real world uncertain situations etc. It also develops the techniques for learning and understanding, which make the computer able to exhibit an intelligent behaviour. The list is exhaustive and is applied nowadays in almost every field of technology. This book presents almost all the components of AI like problem solving, search techniques, knowledge concepts, expert system and many more in a very simple language. One of the unique features of this book is inclusion of number of solved examples; in between the chapters and also at the end of many chapters. Real life examples have also been discussed to make the reader conversant with the intricate phenomenon of computer science in general, and artificial intelligence in particular. **E Kumar, IK International Publishing House Pvt. Ltd., S-25, Green Part Extension, Uphaar Cinema Market, New Delhi 110 016, pp 454, Rs. 245/-.**



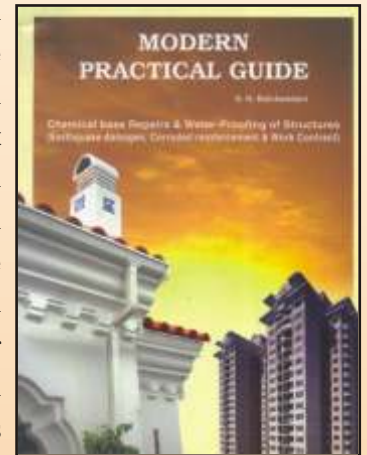
**Fundamentals of Mechanical Engineering :** The textbook explains the fundamentals of mechanical engineering in the areas of thermodynamic, mechanics, theory of machines and strength of materials. The book covers the basics and laws of thermodynamic, thermodynamic cycles, different aspects of applied mechanics that includes machine and mechanism, force system, friction, movement of inertia etc and important areas of strength of materials, that covers stress, strain analysis, bending stress and torsion. Different questions are given from latest competitive examinations. **G S Sawhney, PHI Learning Pvt. Ltd., M-97, Connaught Circus, New Delhi 110 001, pp 827, Rs. 495/-.**

## Book Shelf

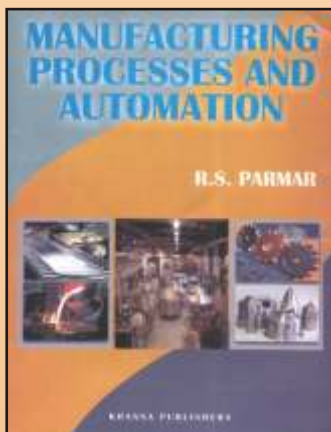


**Electronic Devices and Circuits :** This book could serve as a text book for electronic devices and circuits. It presents a lucid and systematic exposition of the basic principles involved in electron dynamics, semi-conductor diodes and its application, transistors, amplifiers, oscillators and so on. The book also covers 125 practice problems. A question bank with 177 objective type questions is provided. The book also includes solved problems from question papers. **P R Babu**, SCITECH Publications (India) Pvt. Ltd., 7/3C, Madley Road, T Nagar, Chennai 600 017, Rs. 275/-.

**Modern Practical Guide : Chemical Base Repairs and Waterproofing of Structures :** This book has been compiled to bring causes and effects and brief technical background for better understanding of the subject matter at one place. This book has been divided in various chapters. To prevent damages and subsequent repairs, the structure should be designed to withstand such severity of man and nature and this topic had been extensively dealt with in the chapter 'durability'. Durable structures need repairs after passage of time due to environment, misuse and natural calamities like earthquake, fire etc. These topics are also dealt in detail in various chapters along with remedial methodology. Attempt has also been made to provide detailed methodology for waterproofing of water retaining structures such as under ground sumps and overhead tanks. Repairing job involves survey and investigation, preparation of proper documents for tendering, manufacturing of mortar and concrete at site and other ancillary jobs. The book also covers some tips on survey, tender documents including proper nomenclature items of work and most of all, quality control of ingredients of concrete, which will serve to impart basic knowledge. **S H Balchandani**, Monarch Group, 6, Ravipushp App., 3rd floor, B/h, Navneet Prakashan, Gurukul Road, Memnagar, Ahmedabad, pp 206, Rs. 400/-.



**Manufacturing Processes and Automation :** This book has made an attempt to describe all major manufacturing processes that include the conventional as well as established processes and also those, which are comparatively recently appeared on the scene. The book covers basic characteristics of important engineering materials and the methods of their evaluation, heat treatment and also their specific field of application. Extensive coverage has been given to all for basic manufacturing processes, namely, casting, welding, machining and metal working, which includes adequate details regarding setups, working principle, operation and field of application. The last chapter of the book covers basic aspects of automation and its development, which is expected to help in establishment of automated industries in the near future. **R S Parmar**, Khanna Publishers, 4575/15, Onkar House, Ground Floor, Darya Ganj, New Delhi 110 002, pp 559, Rs. 235/-.



### The Privileges of Membership

- Receive IEL's journals, technical monographs, papers, conference proceedings.
- Receive copies of IEL News and Technorama free of charge.
- Access web-based e-groups for professional interaction.
- Access the Engineering Information Service Centre at the Headquarters as well as at the State and Local Centres.
- Participate in continuing education programmes at the Engineering Staff College of India, Hyderabad and at the State and Local Centres.
- Participate in numerous seminars, symposia, conventions, workshops, lectures, conferences, congresses and other events held at national, regional and local levels.
- Participate in international conferences.
- Enjoy facilities and benefits from 24 foreign professional bodies with whom IEL has bilateral relationships.
- Act as arbitrators in arbitration matters relating to engineering jobs and services.
- Share ideas, know-how and experience with fellow members by publishing articles in IEL's journals.
- Receive and stay in retiring rooms available at the Headquarters and at Centres at concessional rates.

### How IEL strengthens your voice

- Speaks on behalf of the engineering profession locally, nationally and globally.
- Connects engineers on wider issues from water infrastructure to sustainable development.
- Coordinates major national and international initiatives.
- Sponsors programmes to foster wider interest in the engineering profession amongst non-engineers.
- Publishes a large number of widely disseminated technical journals.

### Enhance your career with IEL

- Interact with seasoned engineers at IEL Centres. See the choices they have made in becoming leaders and use their perspectives to shape your own leadership style. Build relationships that will last a lifetime.
- Open up new horizons for your career by participating in applied, interdisciplinary fields like rural development, sustainable development, water management, quality and safety, R&D and others.
- Deepen your knowledge and understanding through IEL's continuing education programmes both at the Engineering Staff College of India, Hyderabad and at its Centres.

### How you can enjoy all this and more

- If you have a recognised engineering degree and the necessary professional experience, you can apply for your membership today. And if you are a member and have five years' relevant professional experience, you can even become a Chartered Engineer.
- To apply for membership please log in to our website: [www.ieindia.org](http://www.ieindia.org) for downloading the appropriate form. Or else visit the centre nearest to you.

PRINTED MATTER

If undelivered, please return to :  
The Secretary & Director General  
The Institution of Engineers (India)  
8 Gokhale Road, Kolkata 700 020

REGISTERED

Registration No. 64282/94 with  
The Registrar of Newspapers for India, New Delhi  
Registration No. KOL RMS/177/Jan-March 2010  
Licensed to post without pre-payment No. MM&PO/  
SSRM-KOL RMS/RNP-177/LPWP-038/Jan-March 2010

